



Science **made** smarter

Instructions for Use - EN

AA222



D-0113181-F – 2022/12



Interacoustics

Table of Contents

1	INTRODUCTION	1
1.1	About this manual	1
1.2	Intended use	1
1.2.1	Contraindications for performing impedance audiometry	1
1.3	Product description	2
1.4	Warnings and precautions	3
2	UNPACKING AND INSTALLATION	4
2.1	Unpacking and inspection	4
2.2	Symbols	5
2.3	Important safety instructions	7
2.4	Malfunction	8
2.5	Connections	9
2.5.1	Changing probe system	10
2.5.2	Safety precautions to take when connecting the AA222	10
2.6	License	12
2.7	About Diagnostic Suite	13
3	OPERATING INSTRUCTIONS	14
3.1	AA222 operation panel	15
3.2	Startup	19
3.3	Instrument settings	19
3.4	About	21
3.5	Clients and session handling	22
3.5.1	Clients	22
3.5.2	View historical sessions	23
3.5.3	Save session	24
3.6	Operating instructions – Impedance	25
3.6.1	Calibration cavities	25
3.6.2	Handling and selection of ear tips	25
3.6.3	Probe status	26
3.6.4	Tympanometry test screen	27
3.6.5	Reflex test screen	29
3.6.6	Reflex decay test screen	31
3.6.7	Reflex latency test screen (extended license)	32
3.6.8	Eustachian tube function – Non-perforated eardrum	32
3.6.9	Eustachian tube function – perforated eardrum	34
3.6.10	Eustachian tube function – patulous eustachian tube (extended license)	35
3.7	Operating instructions – audiometry	36
3.7.1	Tone audiometry test screen	36
3.8	Operating in sync mode (only with the Diagnostic Suite)	47
3.8.1	PC power configuration	47
1.1.1.	Starting from OtoAccess®	47
3.8.2	Starting from Noah 4	47
3.8.3	Crash report	47
3.8.4	Instrument setup	48
3.9	Using sync mode	49
3.9.1	Using IMP sync	49
3.9.2	Using AUD sync	51
3.9.3	Sync mode	53
3.9.4	Client upload	53

3.9.5	Session download	54
4	MAINTENANCE	55
4.1	General maintenance procedures	55
4.2	Cleaning the probe tip.....	57
4.3	Repair	58
4.4	Warranty	58
4.5	Periodic calibration	59
5	TECHNICAL SPECIFICATIONS	60
5.1	Calibration properties.....	65
5.2	Reference equivalent threshold values for transducers	69
5.2.1	Impedance - Frequencies and intensity ranges.....	69
5.2.2	Audiometry – Survey of reference and max hearing level tone audiometry.....	70
5.3	Pin assignments	79
5.4	Electromagnetic compatibility (EMC).....	81



1 Introduction

1.1 About this manual

This manual is valid for the AA222 (Model 1078) firmware version 1.11.

The product is manufactured by:

Interacoustics A/S
Audiometer Allé 1
5500 Middelfart
Denmark
Tel: +45 6371 3555
Fax: +45 6371 3522
E-mail: info@interacoustics.com
Web: www.interacoustics.com

1.2 Intended use

Indications for use

The Interacoustics Audio Traveler AA222 is intended for use by trained operators in hospitals, nurseries, ENT clinics and audiology offices in conducting diagnostic hearing evaluations and assisting in diagnosis of possible otologic disorders. The AA222 is a combination of audiometer and tympanometer, which reduces the amount of equipment necessary.

Intended operator

Trained operators like audiologist, hearing healthcare professional, or trained technician

Intended population

No restrictions

1.2.1 Contraindications for performing impedance audiometry

- Recent stapedectomy or other middle ear surgery
- Discharging ear
- Acute external auditory canal trauma
- Discomfort (e.g., severe otitis externa)
- Occlusion of the external auditory canal
- Presence of tinnitus, hyperacusis or other sensitivity to loud sounds may contraindicate testing when high intensity stimuli are used

Tympanometry should not be performed on patients with the above-mentioned symptoms without a medical doctor's approval.

Visual inspection for obvious structural abnormalities of the external ear structure and positioning as well as the external ear canal should be performed before testing.



1.3 Product description

The AA222 consists of the following parts:

Included parts	AA222 instrument
	Power supply unit UES65-240250SPA3
	Operation manual USB including Additional Information
	Multilingual Instructions for Use
	Cleaning cloth
	Clinical probe system and/or Diagnostic probe system ¹
	Contralateral headphone ¹
	Assortment bag BET55
	Floss kit
	Daily check cavity
	Audiometric headset ¹
	Monitor headset
	Bone conductor ¹
	APS3 Patient response ¹
	Optional parts
Wall mount	
CAT50 calibration cavities	
IP30 Insert contra headphone ¹	
TDH39 contra headphone ¹	
Amplivox audiocups, noise reducing headset ¹	
EARTone3A/5A Audiometric insert phones ¹	
IP30 Audiometric insert phones ¹	
HDA300 Audiometric headset with double mono 6.3mm jack ¹	
HDA280 Audiometric headset ¹	
TDH39 Audiometric headset ¹	
DD450 Audiometric headset with ambient noise isolation ¹	
DD65v2 Audiometric headset	
Free field speaker	
Talk back microphone	
Diagnostic Suite software	
OtoAccess® database	

¹ Applied part as according to IEC60601-1



1.4 Warnings and precautions

Throughout this manual, the following definitions of warning, caution and notice are used:



WARNING

The **WARNING** label identifies conditions or practices that may present danger to the patient and/or user.



CAUTION

The **CAUTION** label identifies conditions or practices that could result in damage to the equipment.

NOTICE

NOTICE is used to address practices not related to personal injury.

Federal law restricts the sale, distribution, or use of this device to, by, or on the order of a licensed medical practitioner.



2 Unpacking and installation

2.1 Unpacking and inspection

Keep the shipping box for future shipment

Please store the AA222 shipping box. It will be needed if the instrument has to be returned for service. If service is required, please contact your local distributor.

Inspect before connection

Prior to connecting the product it should be inspected for damage again. All of the cabinet and the accessories should be checked visually for scratches and missing parts.

Report immediately any faults

Any missing part or malfunction should be reported immediately to the supplier of the instrument together with the invoice, serial number, and a detailed report of the problem. In the back of this manual, you will find a "Return Report" where you can describe the problem.

Please use the "Return Report"

Use of the Return Report provides the service engineer with the relevant information to investigate the reported issue. Without this information, there may be difficulty in determining the fault and repairing the device. Please always return the device with a completed Return Report in order to guarantee that correction of the problem will be to your satisfaction.











Storage

If you need to store the AA222 for a period, please ensure that it is stored under the conditions specified in the section for technical specifications.







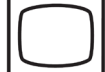

2.2 Symbols

The following symbols can be found on the instrument, accessories, or packaging:

Symbol	Explanation
	Type B applied parts Patient applied parts that are not conductive and can be released immediately from the patient
	Follow instructions for use
	WEEE (EU-directive) This symbol indicates that when the end-user wishes to discard this product, it must be sent to separate collection facilities for recycling
 0123	The CE-mark in combination with MD symbol indicates that Interacoustics A/S meets the requirements of the Medical Device Regulation (EU) 2017/745. Approval of the quality system is made by TÜV – identification no. 0123.
	Medical device
	Year of manufacture
	Manufacturer
	Serial number
	Reference number
	Indicates a component is intended for one use, or for use on a single patient during a single procedure
	Display Port Connection – HDMI type



	"ON" / "OFF" (push-push)
	Keep dry
	Transport and storage temperature range
	Transport and storage humidity limitations
<p>ETL CLASSIFIED</p>  <p>Intertek 4005727 Conforms to ANSI/AAMI BS 60601-1:2005/A1:2 Certified to CAN/CSA-C22.2 No. 60601-1:2011</p>	ETL listing mark
	Logo



2.3 Important safety instructions

Read these instructions carefully and completely before using the product



WARNING



1. This equipment is intended to be connected to other equipment thus forming a Medical Electrical System. External equipment intended for connection to signal input, signal output or other connectors must comply with the relevant product standard e.g., IEC 60950-1 for IT equipment and the IEC 60601-series for medical electrical equipment. In addition, all such combinations – Medical Electrical Systems – must comply with the safety requirements stated in the general standard IEC 60601-1, (edition 3.1), clause 16. Any equipment not complying with the leakage current requirements in IEC 60601-1 must be kept outside the patient environment i.e., at least 1.5m from the patient support or must be supplied via a separation transformer to reduce the leakage currents. Any person who connects external equipment to signal input, signal output or other connectors has formed a Medical Electrical System and is therefore responsible for the system to comply with these requirements. If in doubt, contact a qualified medical technician or your local representative. When the instrument is connected to a PC, or other similar items, beware of not touching the PC and patient simultaneously.
2. A Separation Device (isolation device) is needed to isolate the equipment located outside the patient environment from the equipment located inside the patient environment. In particular such a Separation Device is required when a network connection is made. The requirement for the Separation Device is defined in IEC 60601-1 clause 16.
3. To avoid the risk of electric shock, this equipment must only be connected to supply mains with a protective earth.
4. Do not use any additional multiple socket-outlet or extension cord. For safe setup please refer to section 2.4.2
5. This instrument contains a coin-type lithium battery. The cell can only be changed by service personnel. Batteries may explode or cause burns, if disassembled, crushed, or exposed to fire or high temperatures. Do not short-circuit.
6. No modification of this equipment is allowed without the authorization of Interacoustics. Interacoustics will make available on request circuit diagrams, component part lists, descriptions, calibration instructions, or other information. This will assist service personnel to repair, the parts of this audiometer that are designated by the Interacoustics service personnel as repairable.
7. For maximum electrical safety, turn off the power to a mains- powered instrument when it is left unused.
8. The instrument is not protected against ingress of water or other liquids. If any spillage occurs, check the instrument carefully before use or return for service.
9. No part of the equipment can be serviced or maintained while in use with the patient.
10. Do not use the equipment if it is showing visible signs of damage.



CAUTION

1. Never insert, or in any way use, the insert headset without a new clean and non-defective test tip. Always make sure that the foam or ear-tip is mounted correctly. Ear tips and foam are for single use only.
2. The instrument is not intended for use in environments exposed to fluid spills.
3. The instrument is not intended for use in oxygen rich environments or for use in conjunction with flammable agents.
4. Check calibration if any parts of the equipment are exposed to shock or rough handling.
5. Components marked for “single use” are intended for a single patient during a single procedure, and there is a risk of contamination if the component is re-used. Components marked for “single use” are not intended to be reprocessed.



NOTICE:

1. To prevent system faults, take appropriate precautions to avoid PC viruses and similar.
2. Use only transducers calibrated with the actual instrument. To identify a valid calibration, the serial number for the instrument will be marked on the transducer.
3. Although the instrument fulfils the relevant EMC requirements, precautions should be taken to avoid unnecessary exposure to electromagnetic fields, e.g., from mobile phones etc. If the device is used adjacent to other equipment, it must be monitored to ensure that there is no mutual disturbance. Please also refer to EMC considerations in section 5.3.
4. Use of accessories, transducers, and cables other than specified, with the exception of transducers and cables sold by Interacoustics or representatives, may result in increased emission or decreased immunity of the equipment. For a list of accessories, transducers and cables that fulfil the requirements please refer to section 5.3.

5. Within the European Union, it is illegal to dispose of electric and electronic items in unsorted municipal waste. Electric and electronic waste may contain hazardous substances and therefore has to be collected separately. Such products will be marked with the crossed-out wheeled bin symbol, shown below. The cooperation of the user is important in order to ensure a high level of reuse and recycling of electric and electronic waste. Failing to recycle such waste products in an appropriate way may endanger the environment and consequently the health of human beings.



6. Outside the European Union, local regulations should be followed when disposing of the product after end of life.

2.4 Malfunction



In the event of a product malfunction, it is important to protect patients, users, and other persons against harm. Therefore, if the product has caused, or potentially could cause such harm, it must be quarantined immediately.

Both harmful and harmless malfunctions, related to the product itself or to its use, must immediately be reported to the distributor where the product was acquired. Please remember to include as many details as possible e.g., the type of harm, serial number of the product, software version, connected accessories and any other relevant information.

In case of death or serious incident in relation to the use of the device, the incident must immediately be reported to Interacoustics and the local national competent authority.



2.5 Connections

The back panel contains the connectors (sockets):



1	Probe	Dedicated probe connection
2	Contra	Contra probe connection
3	Assist Mon.	Assisting Monitor (monitor headset)
4	FF1	Free field 1
5	FF2	Free field 2
6	LAN	LAN (Not used)
7	USB A	For printer, mouse, keyboard, memory stick
8	USB B	For PC connection
9	HDMI	For external monitor or projector
10	In 24 V	 Use only specified power supply unit UES65-240250SPA3 type
11	Pat. Resp.	Patient response button
12	Right	Audiometry Right output
13	Left	Audiometry Left output
14	Bone	Audiometry Bone output
15	TF	Talk forward (monitor headset microphone)
16	TB	Talk back
17	CD	CD for CD input



2.5.1 Changing probe system

Change between the standard and clinical probe as follows:



1. Locate the probe connection on the back of the unit.



2. Open the 2 locks by pushing them to the sides.



3. Swap to the other probe system.
4. Close the 2 locks by pushing them to the center.

2.5.2 Safety precautions to take when connecting the AA222



WARNING

Please note that if connections are made to standard equipment such as printers and networks, special precautions must be taken in order to maintain medical safety. Please refer to section 2.3.



WARNING



Use only specified power supply unit UES65-240250SPA3 type.

NOTICE: As a part of data protection, ensure to be compliant to all the following points:

1. Use Microsoft supported operating systems
2. Ensure operating systems are security patched
3. Enable database encryption
4. Use individual user accounts and passwords
5. Secure physical and network access to computers with local data storage
6. Use updated antivirus and firewall and anti-malware software
7. Implement appropriate backup policy
8. Implement appropriate log retention policy



Please follow the instructions below.

Fig. 1. AA222 used with the medically approved power supply UES65-240250SPA3.



Fig. 2. AA222 used with a medically approved safety transformer and a wired connection to a PC.

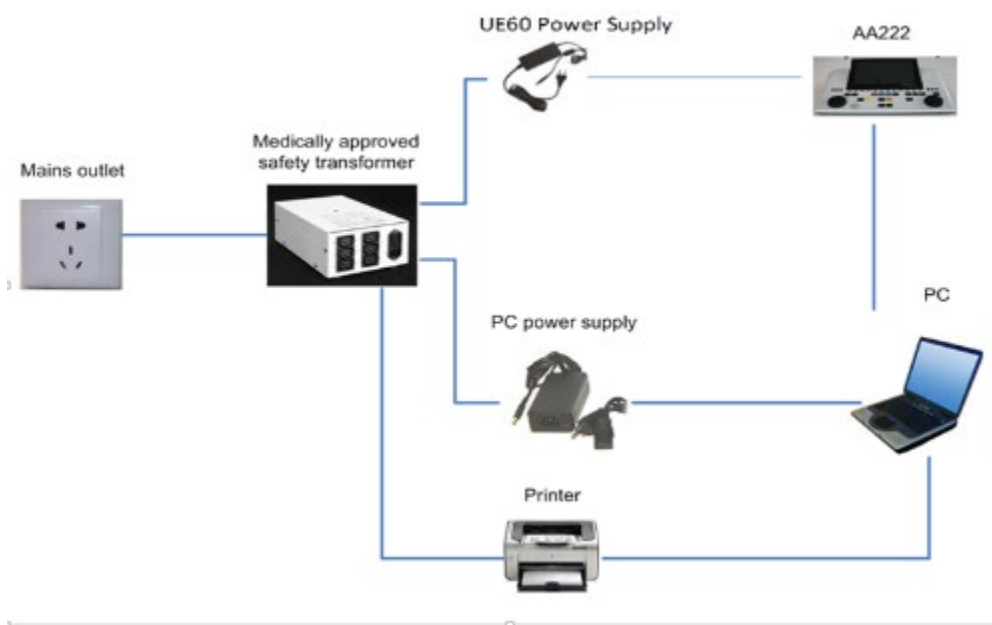



Fig. 3. AA222 used with the medically approved power supply UES65-240250SPA3 and optical USB connection to a PC.

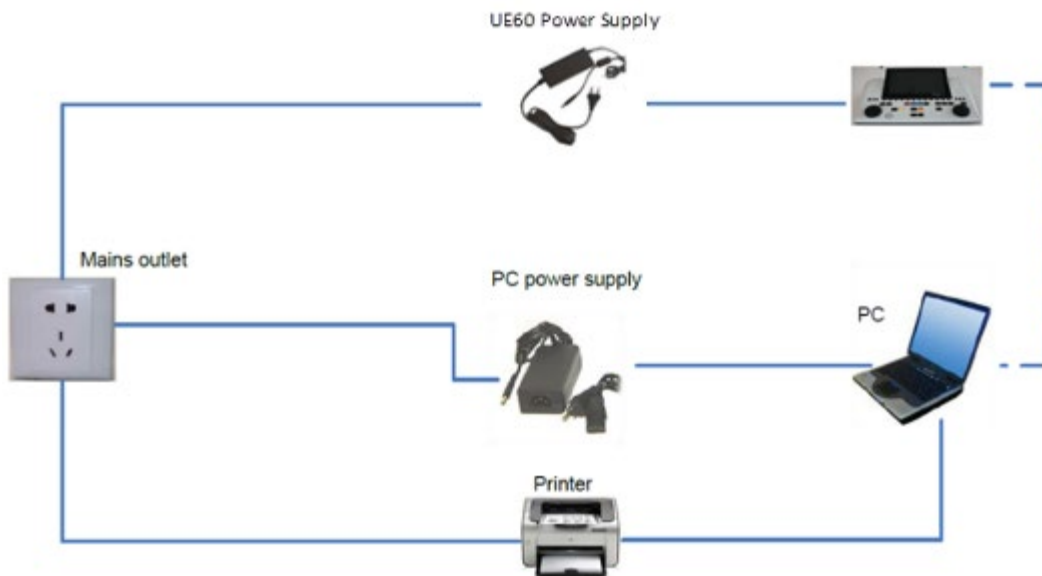
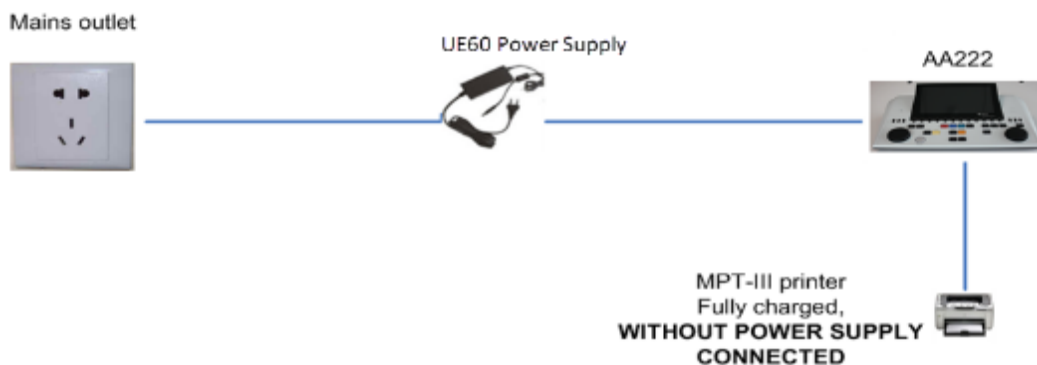

Fig. 4. AA222 used with the medically approved power supply UE60-240250SPA3 and printout with MPT-III printer.



WARNING

The separable mains plug for UES65-240250SPA3 is used to safely disconnect mains from the device. Do not position the power supply in a position so that it is difficult to disconnect the device.

2.6 License

When you receive the AA222, it already contains the license you have ordered. If you would like to add licenses that are available for the AA222, please contact your local distributor.



2.7 About Diagnostic Suite

Should you go to Menu > Help > About then you will see the below window. This is the area of the software where you can manage license keys and check your Suite, Firmware and Build Versions.

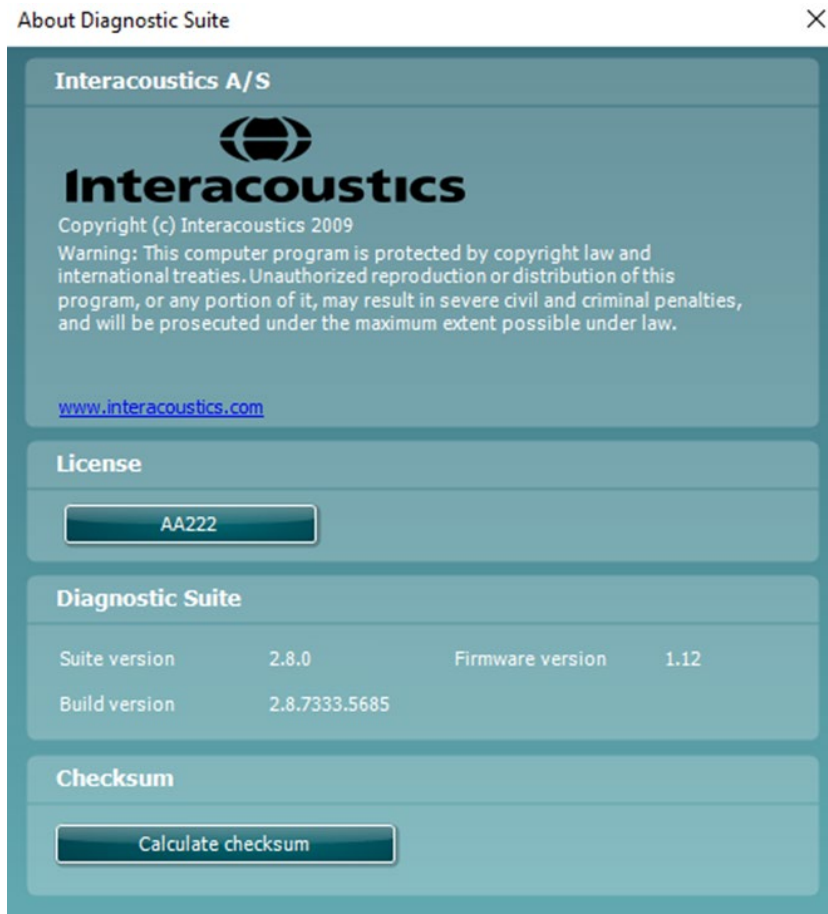

Also, in this window you will find the Checksum section which is a feature designed to help you identify the integrity of the software. It works by checking the file and folder content of your software version. This is using an SHA-256 algorithm.

On opening the checksum, you will see a string of characters and numbers, you can copy this by double clicking on it.



3 Operating instructions

When operating the instrument, please observe the following guidelines:



CAUTION

1. Use this device only as described in this manual.
2. Use only the disposable Sanibel™ ear tips designed for use with this instrument.
3. Always use a new ear tip for each patient to avoid cross-contamination. The ear tip is not designed for reuse.
4. Never insert the probe tip into the ear canal without affixing an ear tip as this may damage the patient's ear canal.
5. Keep the box of ear tips outside the reach of the patient. Risk of choking.
6. Be sure to insert the probe tip in a way which will assure an airtight fit without causing any harm to the patient. Use of a correct and clean ear tip is mandatory.
7. Be sure to use only stimulation intensities acceptable to the patient.
8. When presenting contralateral stimuli using the insert phones – do not insert the phones, or in any way try to conduct measurements, without a correct insert ear tip in place.
9. Clean the headphone cushion regularly using a recognized disinfectant (70% isopropyl alcohol).
10. The presence of tinnitus, hyperacusis or other sensitivity to loud sounds may contraindicate testing when high intensity stimuli are used.

NOTICE

1. Careful handling of the probe system whenever in contact with a patient should be given high priority. Calm and stable positioning while testing is preferred for optimal accuracy.
2. The AA222 should be operated in a quiet environment, so that measurements are not influenced by external acoustic noises. This may be determined by an appropriately skilled person trained in acoustics. ISO 8253-1 Section 11, defines guidelines for permissible ambient noise for audiometric hearing testing.
3. It is recommended that the instrument be operated within an ambient temperature range of 15°C/59°F-35°C/95°F.
4. The headphone and insert phone are calibrated to the AA222 – introducing transducers from other equipment requires a re-calibration.
5. Never clean the transducer housing with water or insert non-specified instruments into the transducer.
6. Do not drop or cause any other undue impact to this device. If the instrument is dropped or in any other way damaged, return it to the manufacturer for repair and/or calibration. Do not use the instrument if any damage is suspected.



3.1 AA222 operation panel



Name	Description
1	⏻ Turns the AA222 ON/OFF.
2	Shift The shift key activates the sub functions of the other keys.
3	Clients Press the Clients button to open a window in which a client can be selected, edited, or created. Also, its historic sessions can be viewed.
4	Setup Hold down Setup and use the wheel (19) to select the desired Setup menu then let go of the Setup button to open it.
5-14	Function keys The 10 function keys hold functions displayed on the screen directly above the individual F-key
15	Tests Hold down Test and use the wheel (34/38) to select the desired protocol with the module or switch between the audiometry and impedance module. Let go of the Test button to make your selection.
16	Del Point Delete points during audiometry testing. <i>Del curve</i> Delete the entire audiometry threshold curve of a graph by holding 'shift (2)' together with this button.
17	Save session Saves the current session including audiometry and impedance measures. New session Create a new session by pressing 'shift (2)' together with this button. A new session will recall the default settings.
18	Print Prints the session that is currently selected to the printer setup in the Instrument settings.



- 19 Tymp Enters the impedance module and adds or removes a tympanometry measure to the protocol.
- 20 Reflex Enters the impedance module and adds or removes an ipsi lateral or contra lateral reflex test protocol.
- 21 Right Selects right test ear, and toggles between headset and insert earphone transducers. Ensure the correct transducer (headset or insert phones) is plugged in (back panel, 12). If the audiometer is only calibrated with one of the transducers, the button cannot be used for toggling.
- 22 Left Selects left test ear, and toggles between headset and insert earphone transducers. Ensure the correct transducer (headset or insert phones) is plugged in (back panel, 13). If the audiometer is only calibrated with one of the transducers, the button cannot be used for toggling.
- 23 Bone Press this button to use the bone conductor for audiometry. First push selects the right ear for testing, while the second push selects the left ear for testing. The light above the button will indicate the ear selected.
- 24 FF Press '1 FF 2' to select the free field speaker as output for Channel 1. First push will present the sound through Free Field speaker 1, while second push will present the signal through Free Field speaker 2.
- 25 Tone/Warble Pressing this button once or twice enables toggling between pure tones or warble tones during audiometry. The stimuli chosen will be shown on the display, e.g.

Right - Warble tone



- 26 Speech Allows for presentation of speech material using wave files or a CD input. The speech material must be installed and set up in the Speech settings.

When setup for CD, by pressing the function once or twice it is possible to have recorded speech in either channel 1 or channel 2 separately.

If setup for CD, pressing this button for one second will allow for adjustment of the gain output. Gain 1 using wheel (34) and gain 2 using wheel (38).



- 27 Mic Mic allows for presentation of speech using the microphone. The VU meter can be seen on the screen.

Adjust the microphone gain by pressing this button while adjusting the wheel (34).



- 28 Monitor/TB Monitor/TB activates the monitor and Talk Back (TB) for speech feedback from the patient in the test cabin.



With the activation of this monitor, presentation to the patient from e.g., CD can be heard through the built in monitor of the AA222 or monitor headset.

Adjust the monitor gain by long pressing on the button. Channel 1 using wheel (34), channel 2 using wheel (38).

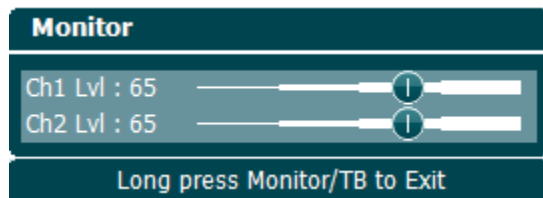

Adjust the Talk Back (TB) gain by long pressing the button and press it one more time. Both wheels (34/38) can be used to adjust the gain.

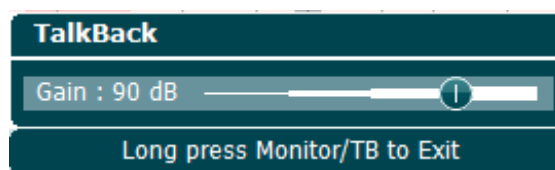

Long press to exit the gain adjustment when finished.

- | | | |
|----|--------------------------------------|---|
| 29 | No Resp. | Allows for storage of a no response when the patient does not respond to the presented tone/signal. |
| 30 | Store | Stores manually obtained thresholds (e.g., during pure tone audiometry and speech audiometry). |
| 31 | Talk Forward | Allows for communication with the patient, talking through the microphone by the operator and heard by the patient in the selected transducer headset. |
| 32 | Ext. Range | Allows for testing at higher intensity levels during audiometry. The light above the button will turn slightly orange when Extend Range is available and will be fully lit once this button is pressed and the function is activated. |
| 33 | Mask on/off | Turn the masking through channel 2 on/off; first push turns masking on, second push turns masking off. The light above will indicate if the masking is on (lit) or off (unlit). |
| 34 | Wheel | The wheel is multifunctional. It is used for adjusting the level of the output for channel 1 during audiometry, for manual pump control during impedance measures, and to scroll through menus and selection options. |
| 35 | Tone Switch,
Enter,
Start/stop | Used for tone switch in audiometry. In tympanometry it interrupts or starts the auto-start function, and it operates as a stop and start button while the probe is in an ear. In menus that require textual input the tone switch is used for making selections. |
| 36 | Down/Incorrect | Down is used to decrease in frequency during audiometry.

Incorrect is used during speech audiometry for storing an incorrect word. The AA222 has an incorporated automatic speech score counter. Therefore, as a second function you can use this button as an "Incorrect" button when performing speech tests. For automatic speech score counting while testing speech, push this button after each word not heard correctly by the patient. |



- 37 Up/Correct Up is used to increase in frequency during audiometry.
Correct is used during speech audiometry for storing a correct word. The AA222 has an incorporated automatic speech score counter. Therefore, as a second function you can use this button as a “Correct” button when performing speech tests. For automatic speech score counting while testing speech, push this button after each word heard correctly by the patient.
- 38 Wheel Adjust the level of the output for channel 2 used for masking during audiometry.
Change the reflex frequency during manual reflex measures and scroll through menus and selection options.
- 39 Talk forward microphone For talk forward instruction to the patient in the test cabin when the talk forward button is pressed.
The microphone used for talk forward is TF (15, back panel) as first priority. If a microphone is not plugged in, the internal microphone (39) will be used.
The intensity is changed by turning the wheel (34) while holding the ‘Talk Forward’ button.

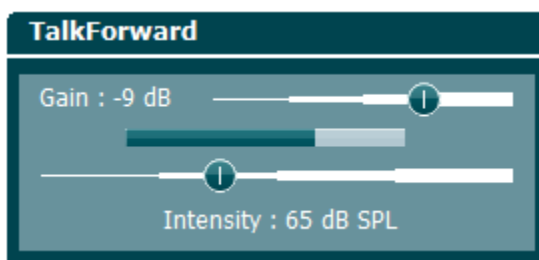

- 40 Monitor speaker The monitor speaker monitoring both channels together is available by selecting the “Monitor” button (28), if an assisting monitor headset is not plugged in (3, back panel).



3.2 Startup

The AA222 will always load the latest protocol and will start in the startup screen set in instrument settings - Aud or Imp.

3.3 Instrument settings

Instrument settings is shared for the audiometry and impedance modules and contains all the general settings including license, light, date and time, and printer settings.

Hold the **Setup** button (4) and select **Instrument Settings** by rotating the wheel (34/38).

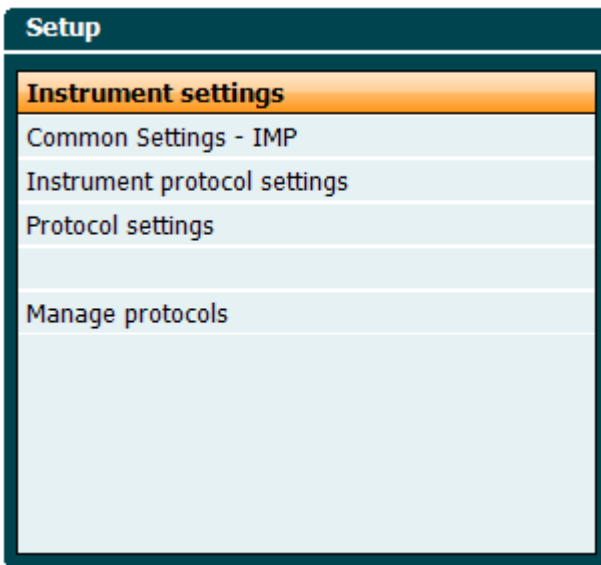

Impedance module

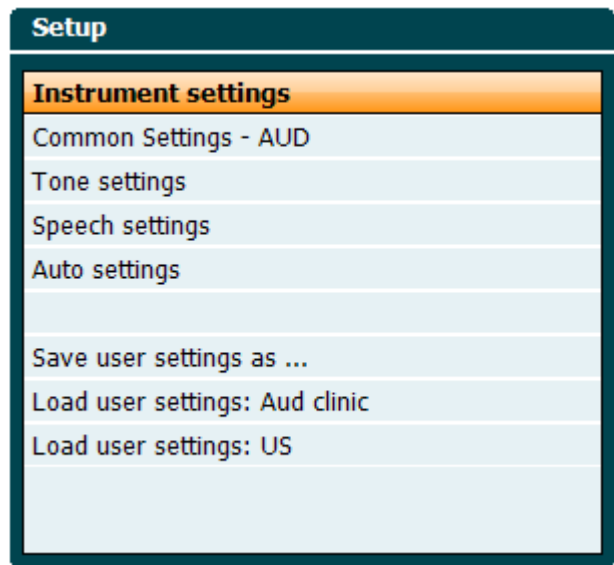



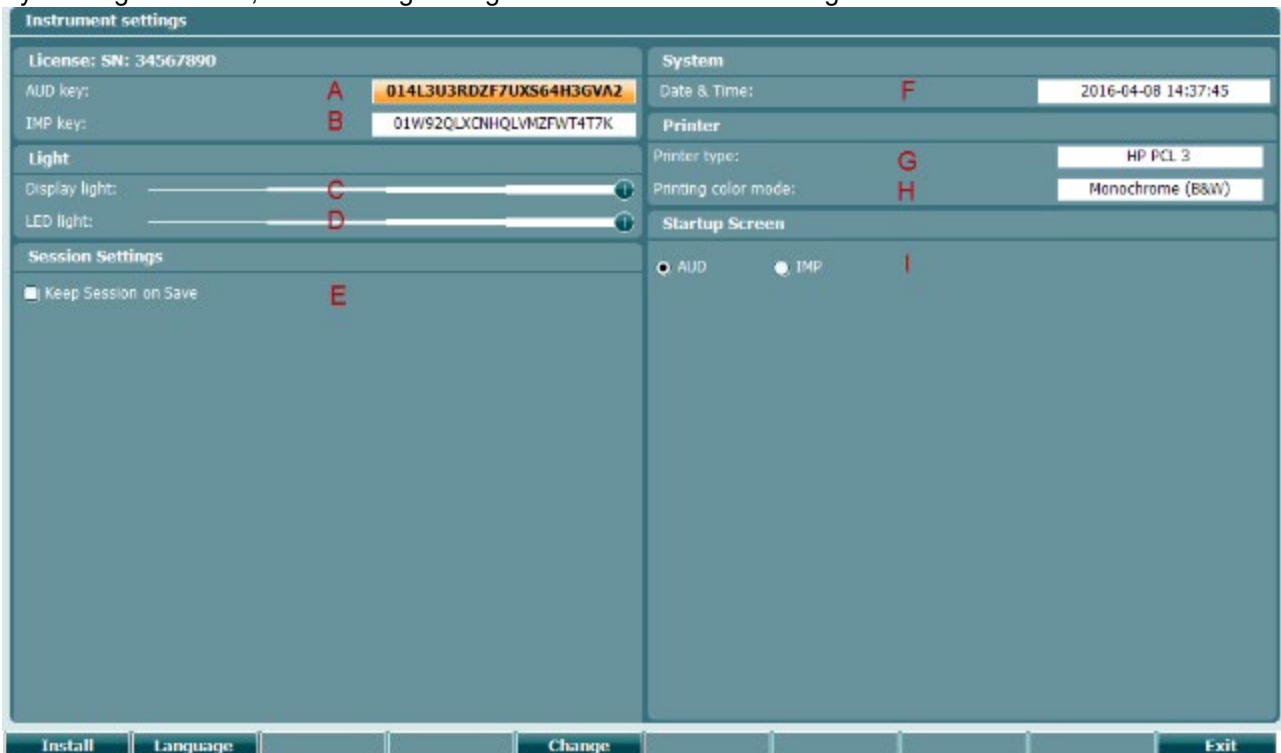

Audiometry module

By rotating the wheel, the following settings can be selected and changed:







License

- A **AUD key**. When pressing the  button a pop up window opens in which you can enter a new license key for the audiometry module. The new license key is activated by pressing the  button. The previous license key will not get changed if the new key is not a valid key.
- B **IMP key**. When pressing the  button a pop up window opens in which you can enter a new license key for the impedance module. The new license key is activated by pressing the  button. The previous license key will not get changed if the new key is not a valid key.

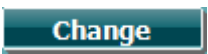
Light

- C The **Display light** can be changed by holding the  button and rotating the wheel. You will see the brightness of your screen change according to this setting.
- D The **LED light** can be changed by holding the  button and rotating the wheel. You will see the brightness of the LEDs around the **Enter** button change according to this setting. Note that the LED in the probe system cannot be adjusted.





Session settings

- E **Keep session on save** will keep the session on the device when pressing save session.

System

- F When pressing the  button while **Date and time** is selected you can manually alter the date and time. The following window will pop up



Use the wheel to select day, month, year, hour, or minutes. Use the  and  buttons to adjust the number. Press the  button to keep changes and set date and time or press the  button to reject any change made. If the AA222 is connected to the Diagnostic Suite, your PC will automatically update the date and time.

Printer

- G Under **Printer type** you can select which printer is connected to the USB port of your AA222. By default, the Sanibel™ MPT-III thermal printer is selected. The list below shows the printers currently supported.

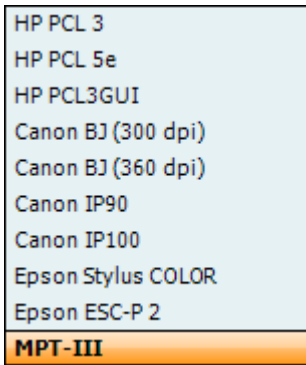

H Under **Printer color mode** you can select if your printer should print in black and white or 3 color (CMY) or 4 color (CMYK) mode.

Startup screen

I Select the startup screen for the device Aud or Imp

In addition, the following buttons are available:



Pressing **Install** allows you to install new firmware on the AA222. When pressing **Install**, the instrument will look for a USB dongle. If there are one or more installation files available, the installation will commence after confirming this action.



Holding the **Language** button and rotating the wheel (34/38) allows selecting one of the available languages. Note that the system needs to be restarted before the new language setting is used.



Press **Exit** to leave Instrument settings

3.4 About

Shift+Setup opens the following 'About' box that provides information about the firmware OS version, DSP version and license configuration. In addition, it states which transducers the device is calibrated with.

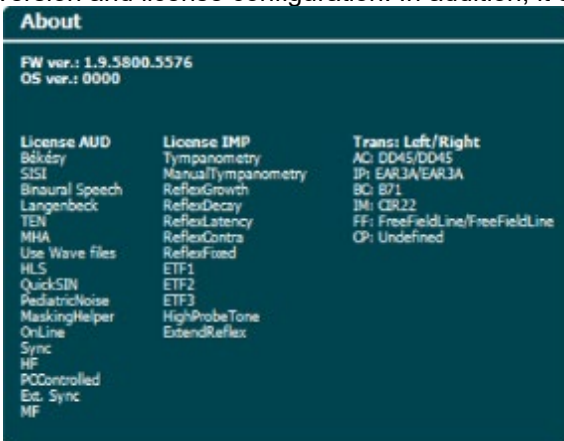



3.5 Clients and session handling

3.5.1 Clients



- Delete** Delete the selected client
- Edit** Edit the selected client
- Back** Return to the session
- Select** Access the sessions saved under the selected client
- View** View a historical session

Use the **wheel** (34/38) to select a client from the list and press **Enter** (35) Save to confirm that data must be saved for the selected client. Before saving the session, you may edit an existing client or create a new client by pressing the **Edit** button or the **New** button. The process of entering client details is as follows:



Use the **wheel** to scroll and use **Enter** to select to type in the client ID. Press **Next** to proceed.



Use the **wheel** to scroll and use **Enter** to select the letter to be inserted for the client's first name. Clear, backspace, shift, caps lock and spacebar functions are found under the soft key buttons.





Press **Next** to proceed.

The screenshot shows a screen titled "Enter family name" with a text input field containing a hyphen. Below the input field is a virtual keyboard with three rows of letters: the first row contains q, w, e, r, t, y, u, i, o, p; the second row contains a, s, d, f, g, h, j, k, l; and the third row contains z, x, c, v, b, n, m.

Follow the procedure as above to enter the family name.

Press **Next** to proceed.

Press **Save** to save the client.

3.5.2 View historical sessions

Press the **Clients** button (3) and use the **wheel** (34/38) to scroll between clients. Select the client by pressing **Select** and a list of available sessions will appear. Use again the **wheel** (34/38) to highlight the session that needs to be selected. Press **View** to show the historical session.

The first screenshot, titled "Clients", shows a list of client information with the following entries:
ID: 333333
Name: Carrie Harris
ID: 111111
Name: Paul Smith
ID: 22222
Name: Pam Mitchell
ID:
Name: NoName
The second screenshot, titled "Clients - Select settings", shows a list of sessions with the following entries:
IMP 12-09-2013 Start time: 12:32
IMP 12-09-2013 Start time: 12:32
IMP 12-09-2013 Start time: 12:33 (highlighted)

Use the **Next** or **Tests** button to browse through the tests within the session. Return to the test screen by pressing **Back**. Press **Trans.** to transfer the session selected to current session for audiometry. The transferred session can be used as a reference when obtaining the current session.

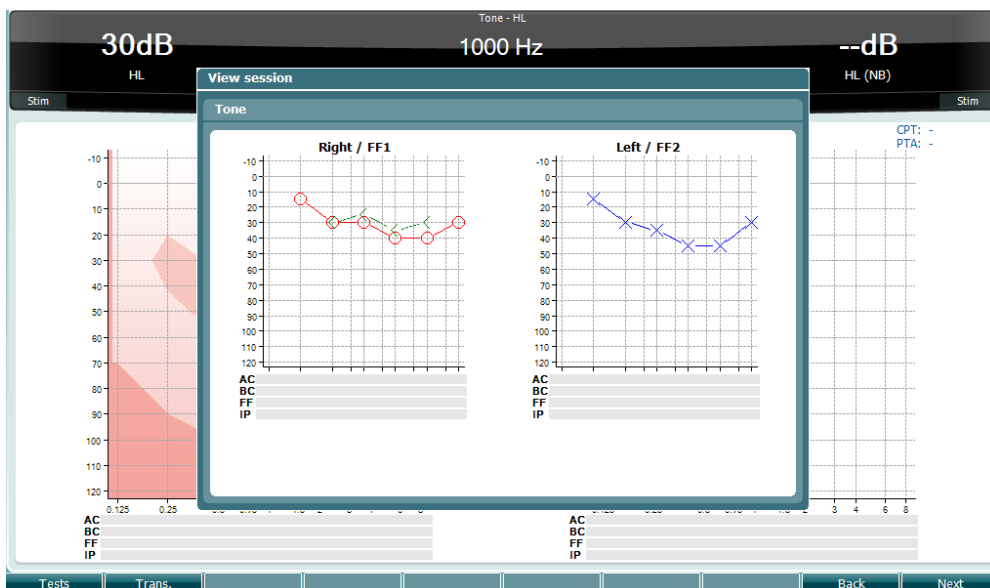



3.5.3 Save session

When pressing **Save Session** the names of the clients created will appear in a list. The session can be saved to an existing client, or a new client can be created.

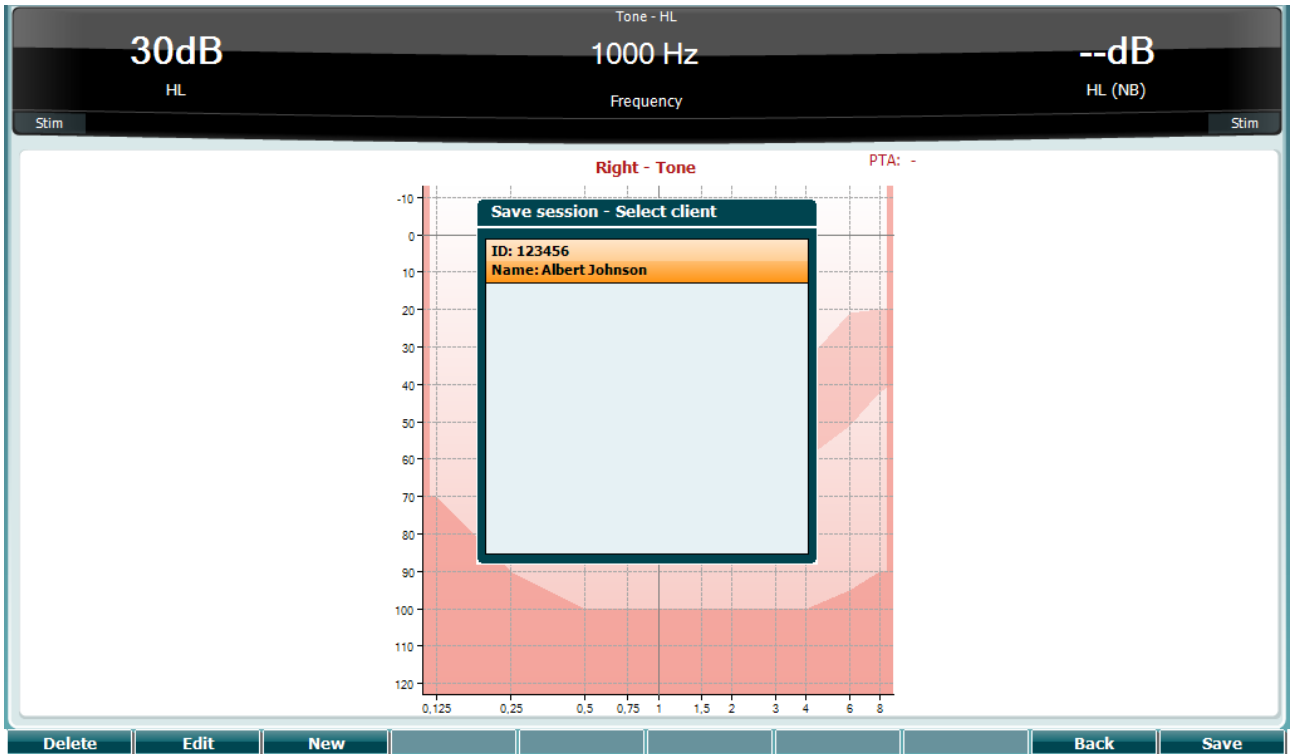

- | | |
|---------------|--|
| Delete | Delete the selected client |
| Edit | Edit the selected client |
| New | Create new client |
| Back | Return to the session |
| Save | Save session under the selected client |



3.6 Operating instructions – Impedance

3.6.1 Calibration cavities

You can use the 0.2ml, 0.5ml, 2.0ml and 5ml for v daily validity checking of the probe calibration.

To perform a calibration check, select a protocol that measures a tympanogram.

Do not use an ear tip! Place the probe tip completely into the cavity. Perform the measurement. Check the volume that was measured.

The permitted tolerance in the volume measurement is ± 0.1 ml for cavities up to 2ml and $\pm 5\%$ for larger cavities. These tolerances are applicable for all probe tone frequencies.

We strongly recommend calibrating probe and contra phone at least once a year.

3.6.2 Handling and selection of ear tips

When using the AA222 probe and CIR contra phone, Sanibel™ ear tips must be used.



CAUTION

The Sanibel™ ear tips are single use only and should not be reused. Reuse of ear tips can lead to the spread of infection from patient to patient.

The probe and CIR contra phone must be fitted with an ear tip of a suitable type and size before testing. Your choice will depend on the size and shape of the ear canal and ear. Your choice may also depend on personal preference and the way you perform your test.



When performing a quick impedance screening test you may choose an umbrella-shaped ear tip. Umbrella ear tips seal the ear canal without the probe tip going into the ear canal itself. Press the ear tip firmly against the ear canal so that a good seal is maintained throughout the entirety of the test.

















For more stable testing, we recommend using an extension cord with a mushroom-shaped ear tip. Make sure that this ear tip inserts completely into the ear canal. Mushroom-shaped ear tips allow you to test 'hands free' from the AA222. This reduces the chance of contact noise disturbing the measurement.

To optimize the stability of the measurements, it is recommended to not hold the probe between the fingers during the? Testing. Acoustic reflex measurements, in particular, could be affected by probe movements.



3.6.3 Probe status

The probe status is indicated by the color of the light on the control panel, the standard probe system, and the clinical probe system. Below, the colors and their meanings are explained:

Color	Control panel	Standard probe	Clinical probe	Status
Red				Right ear is selected. Probe is out of the ear.
Blue				Left ear is selected. Probe is out of the ear.
Green				Probe is in the ear and a seal is maintained.
Yellow				Probe is in the ear and is blocked, leaking or too noisy.
White				The probe has just been attached. Probe status is unknown. If the probe light stays white in any other situation, the AA222 may need to be switched off and back on again to regain proper probe status.
Blinking				The AA222 is pausing and/or an interaction is expected. The AA222 will, for example, remain blinking green if the protocol has finished testing and the probe is still in the ear. Or the user may pause the AA222 before inserting the probe, resulting in blue or red blinking.
No light				AA222 is not monitoring the probe status.



To start and stop an impedance test

After start-up, the AA222 is ready to automatically start a measurement as soon as it detects that the probe is in the ear. When the probe is in the ear, the test can be manually stopped (or paused) and then started again by pressing the “Start/stop” button (35) or by pressing the probe button. When the probe is out of the ear, the test can be stopped (as if it is paused before inserting the probe) or started by pressing the “Start/Stop” button (35). Using the probe button while the probe is out of ear will result in changing the selected ear side and at the same time restoring the automatic start function if necessary.

3.6.4 Tympanometry test screen

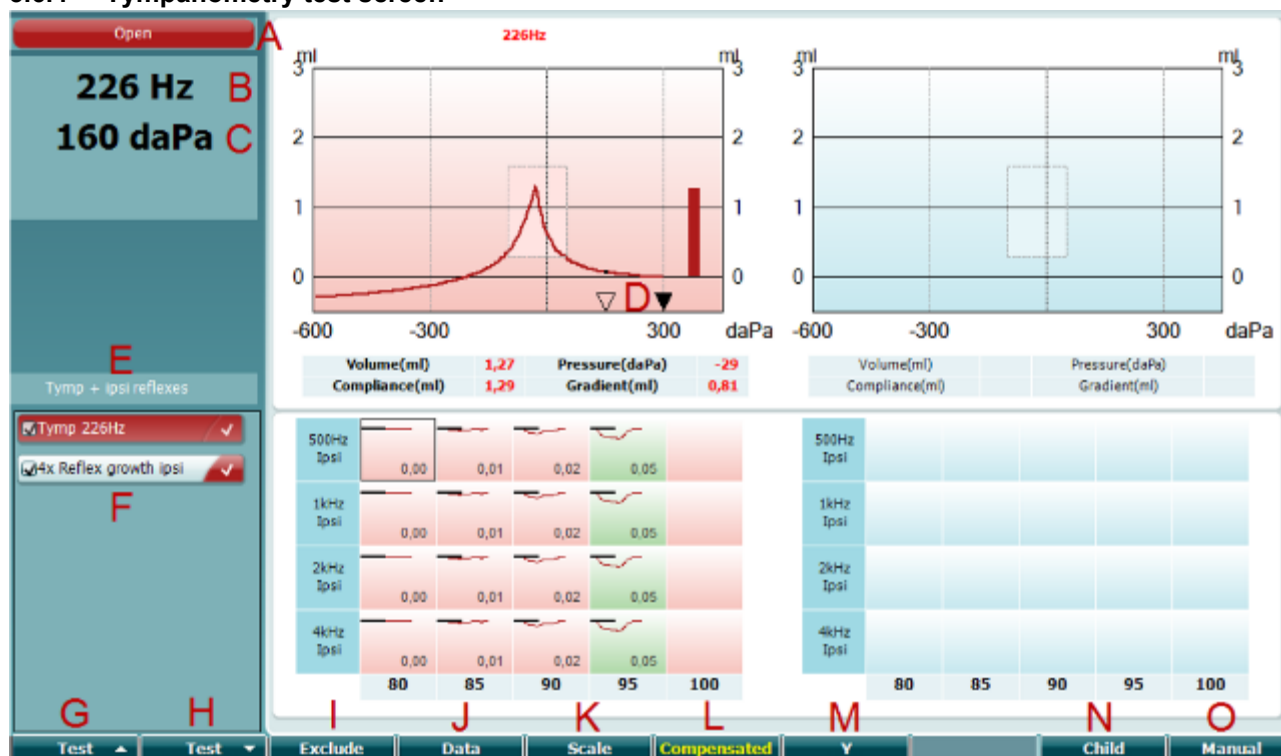

Function Key

Description

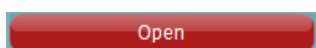

A Probe status showing the color corresponding to the probe light as described in paragraph 3.1. It shows the labels: in ear, out of ear, leaking or blocked.

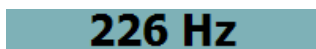

B Probe tone frequency.

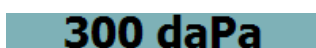

C The current pressure is indicated in daPa.



D The open triangle shows the current pressure. The solid triangle (in manual mode (O) only) shows the target pressure.

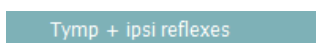

E The name of the current protocol.

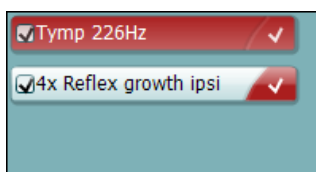

F Protocol list showing which test is currently viewed and, in the check, boxes which tests will be administered after starting a test.

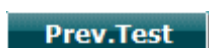

G Press Prev. Test to select the previous test in the protocol list.



Next Test

Include

Exclude

Data

Scale

Compensated

Y

Child

0 daPa

Manual

Auto

- H Press Next Test to select the next test in the protocol list.
- I Press Include to select or Exclude to deselect the checkbox of the currently viewed test (F) and thereby include or exclude it from testing.
- J When several measurement attempts have been carried out pressing Data allows choosing which data set is on view. Only the viewed data can be saved to a client.
- K Pressing Scale allows changing the scale of the compliance axis in the tympanogram.
- L Pressing Compensated allows activating or deactivating the compensation of the tympanogram according to the estimated ear canal volume.
- M Pressing Y allows toggling between screen views of the so called Y, B or G tympanograms. The one shown currently shown is recognized by the capital in the button label.
- N Pressing Child activates a train that will move across on the lower part of the screen to help distract the child while obtaining the measure.

Pressing 0 daPa results in quickly setting ambient pressure as the target pressure and quickly pumping back to 0 daPa. This function is only available in manual mode (O).
- O Activating manual mode in the tympanogram test allows setting the pressure manually with the wheel (19). Press the attenuator (22) to start and stop recording in manual mode. Switching manual mode off and returning to automatic testing is done by pressing Auto.



3.6.5 Reflex test screen

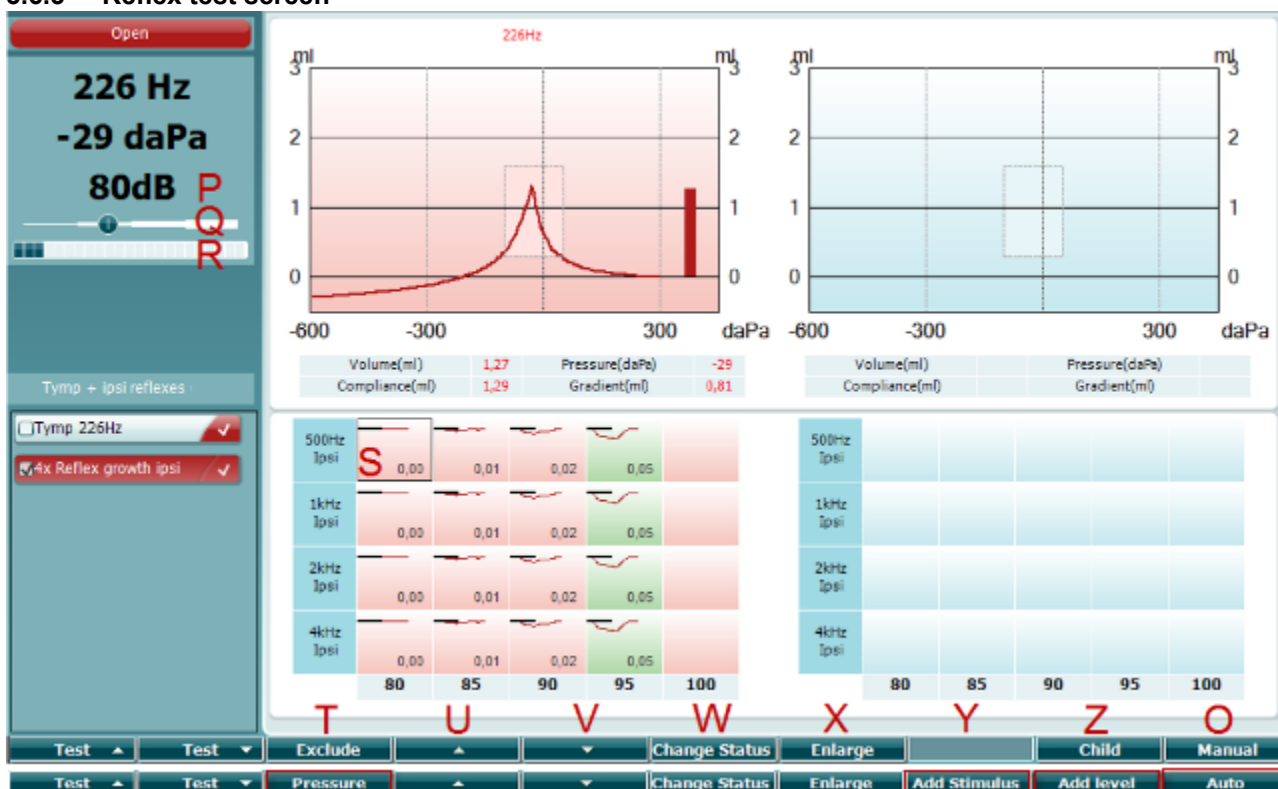

The upper bar of the soft keys indicates the function in auto mode, while the lower bar shows the function for the soft keys in manual mode.

Function Key

Description



O Activating manual mode in the reflex test allows single reflex measurements at a time and optionally the pressure at which the reflex is measured can be manually set (see T).

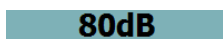

P The number indicates the reflex activator intensity of the currently selected reflex measurement (Q).



Q The pressure slider gives an indication of which pressure reflex measurements are set to be tested (in manual mode (O) only). The slider is moved by holding the pressure button (see T) and turning the wheel.



R The compliance meter gives an indication of the current non-compensated compliance value and can be used to help set the pressure at peak pressure or at an offset from peak pressure (in manual mode (O) only).

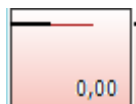

S The currently selected reflex measurement is indicated by the prominent rectangle around it. Within the reflex graph the numerical deflection value is also displayed.



T Pressing Pressure allows setting the pressure manually (see Q) (in manual mode (O) only).



Press Exclude to exclude the highlighted test. Once excluded, press Include to reinstate it as part of the measure.



U Pressing the arrow up button moves the reflex selection to the previous reflex row. Moving the selection sideways is done with the wheel (19).



V Pressing the arrow down button moves the reflex selection to the next reflex row. Moving the selection sideways is done with the wheel (19).

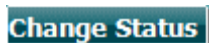

W Pressing Change Status toggles the status of the currently selected reflex (Q). Green indicates that a reflex is present while red/blue indicates that the reflex is not present.



X Holding the Enlarge button shows the currently selected reflex (Q) in highest available detail.



Y Pressing Child activates a train that will move across on the lower part of the screen to help distract the child while obtaining the measure.

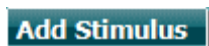

In manual mode (O) the Add Stimulus button is available and allows adding new reflex rows.

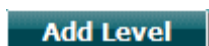

Z In manual mode (O) the Add Level button is available and allows including additional test intensities.



3.6.6 Reflex decay test screen

Note that in cases where your protocol has no reflex decay test included, you can temporarily include a reflex decay test to your protocol by holding the **Shift** button while pressing the **I Reflex C** button. Pressing this combination also allows including and excluding a reflex decay test from running automatically.

The decay test will be automatically performed with an activator intensity of 10 dB above the reflex threshold. The test will show a pop up and ask for the intensity of the activator in cases where:

- within the same protocol, the reflex threshold cannot be found
- the required intensity is at or above the warning level as set up in the protocol settings
- the required intensity is above the maximum intensity that the transducer allows to be played for this particular activator

The default display of the reflex decay tests shows the graphs of the decay measurements which are measured on the selected ear. The following information is found in the display:

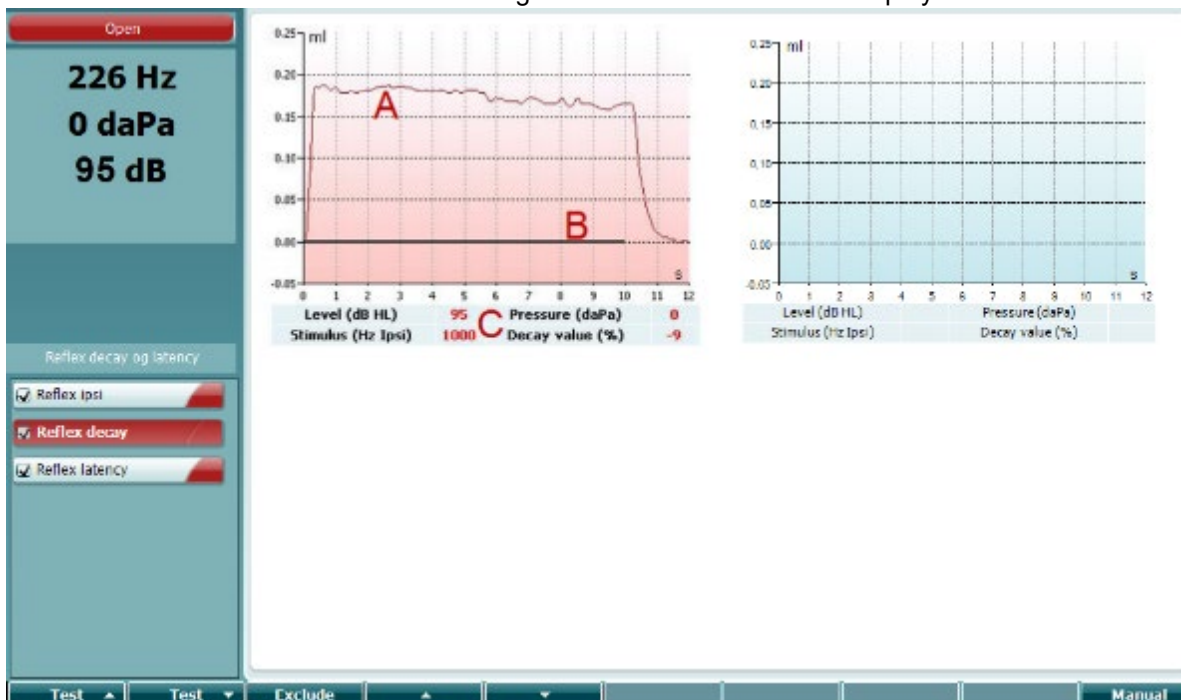

A The tympanometry curves.

B Within the graph, the x-axis is the time scale on which the black bar indicates when the stimulus was given.

C The table with measurement values which are only calculated if the measurement could be completed.

- **Level**, stimulus level
- **Pressure**, the pressure at which the decay reflex is measured. Usually, the Decay test will be set up to use the peak pressure of a preceding tympanogram.
- **Stimulus**, stimulus frequency
- **Decay Value**, the decay value is the percentage difference of the two reflex deflection values taken half a second after the stimulus started and half a second before the stimulus stopped. If decay is present, the percentage shows as a negative number. When the calculation results in numbers larger than 125% or smaller than -115% the outcome is invalid and will not be shown.



3.6.7 Reflex latency test screen (extended license)

The reflex latency test will be automatically performed with an activator intensity of 10 dB above the reflex threshold. The test will show a pop up and ask for the intensity of the activator in cases where:

- within the same protocol, the reflex threshold cannot be found
- the required intensity is at or above the warning level as set up in the protocol settings
- the required intensity is above the maximum intensity that the transducer allows to be played for this particular activator

The default display of the reflex latency test, shows the graphs of the latency measurements which are measured on the selected ear. The following information is found in the display:

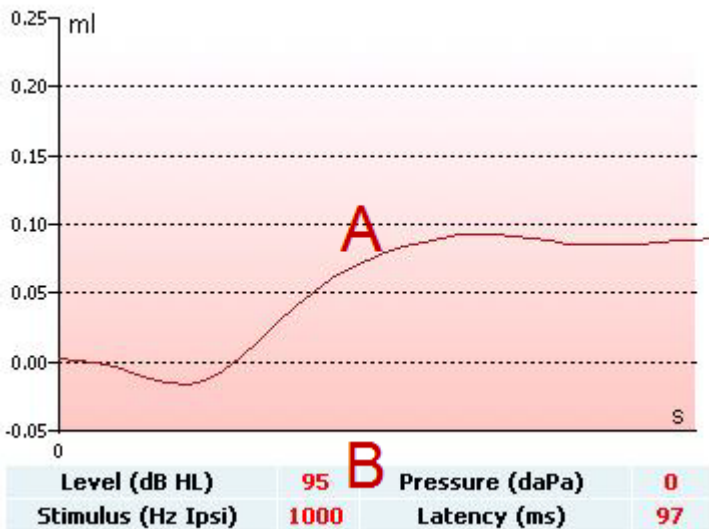

A The first 300ms of the tympanometry curve.

B The table with measurement values which are only calculated if the measurement could be completed.

- **Level**, stimulus level
- **Pressure**, the pressure at which the decay reflex is measured. Usually, the Decay test will be set up to use the peak pressure of a preceding tympanogram.
- **Stimulus**, stimulus frequency
- **Latency Value**, the latency value is the time interval between onset of the stimulus and the point where 10% of the reflex deflection value is reached. The reflex deflection value is measured as the average of the deflection between 250 and 300ms after stimulus onset.

3.6.8 Eustachian tube function – Non-perforated eardrum

The display of the Eustachian tube function test for the non-perforated eardrum shows graphs for the selected ear in which the three tympanograms of the adapted Williams procedure are plotted. The Williams procedure keeps the pressure in between the first and second tympanogram at stop pressure, and between the second and third tympanogram at the start pressure. In between all tympanograms the original Williams procedure is to ask the patient to swallow. In order to get a bigger displacement of tympanograms, we advise asking the patient to perform a Valsalva's maneuver after the first tympanogram and to swallow after the second tympanogram.



The following information is available during testing:

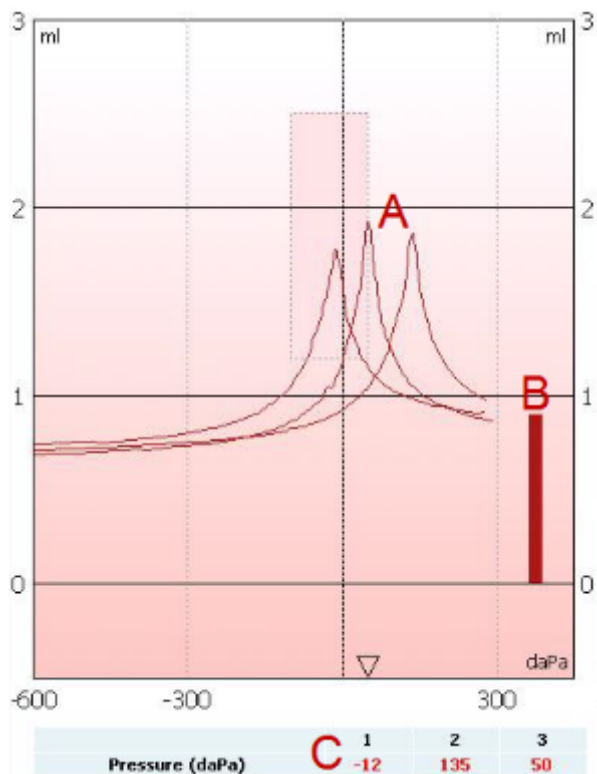

- A The non-compensated tympanometry curves.
- B The equivalent ear canal volume where the acoustic admittance (Y) at the starting pressure of the first tympanogram is taken as the reference value.
- C The table shows the pressure values at which the three peaks are detected (or the highest equivalent volume if there is no peak).

In between the three tympanograms an instruction pops up to tell you how to instruct the patient. Press **Continue** or touch the **Enter** button to continue.

Pause

Please ask your patient to perform the Valsalva maneuver before continuing the next measurement.

Pause

Please ask your patient to swallow before continuing the next measurement.



3.6.9 Eustachian tube function – perforated eardrum

The default display of the Eustachian tube function test for the perforated eardrum shows a graph for the selected ear. The following information is available during testing:

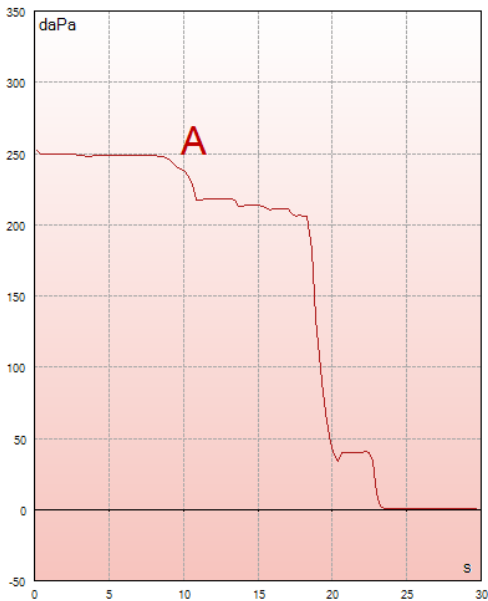

- A The pressure curve showing that the pressure drops each time the patient swallows. Notice that an exponential release of pressure means that the probe seal might not be sufficient.

Before the measurement starts an instruction pops up to tell you how to instruct the patient. Press **Continue** or touch the **Enter** button to continue.

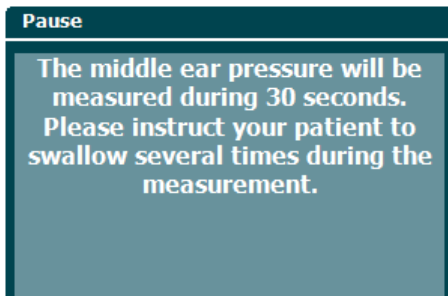



3.6.10 Eustachian tube function – patulous eustachian tube (extended license)

Basically, the Patulous Eustachian Tube test is an impedance baseline test. It monitors changes in impedance over time without applying pressure changes or acoustic stimuli. When a patulous Eustachian tube is present you would typically expect to recognize the breathing of the patient in the tympanometry curve. If the Eustachian tube is closed and the tympanic membrane is intact you expect to measure small tympanometry changes which can be caused by acoustical disturbances from around the patient, accidental displacements of the probe, or by spontaneous movements of the eardrum. Further it allows measuring movements due to the heart beat in for example a glomus tumor. Or the test can be used to measure reflexes where the stimulus is presented through an external device like a cochlear implant.

The default display of the Eustachian tube function test for the patulous Eustachian tube shows the graph for the selected ear. Below is an example of a measurement in which the breathing rhythm of the patient can be recognized due to the presence of a patulous Eustachian tube.

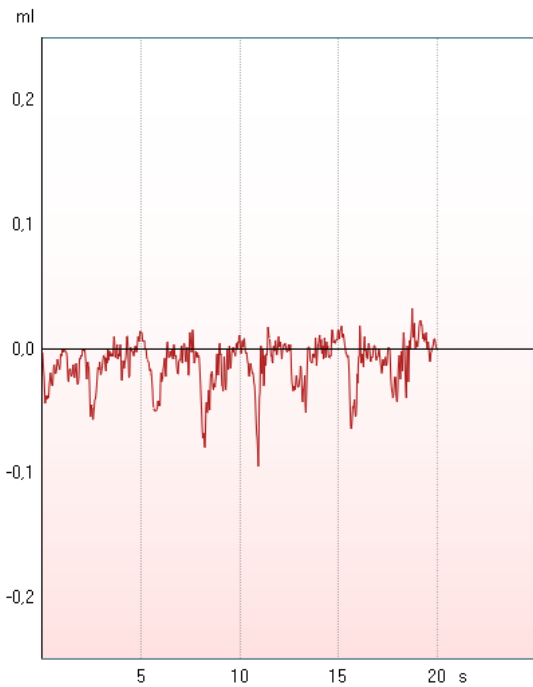



3.7 Operating instructions – audiometry

The audiometry module contains the following tests, which can be selected from the list of tests (15), by rotating the wheel (34/38).

- Tone
- Stenger
- Weber
- ABLB – Fowler
- SISI – Short increment sensitivity index
- Auto – Hughson Westlake
- Speech
- Speech Ch2On (extended version only)
- Speech in noise
- QuickSIN – Quick speech in noise (optional)

Please note that the tests available in this list depend on the license configuration.

3.7.1 Tone audiometry test screen

The Tone audiometry test screen is used for tone audiometry via normal headphones or insert phones, bone conduction, or free field speakers. Below is a description of the functionalities in the tone audiometry test screen.

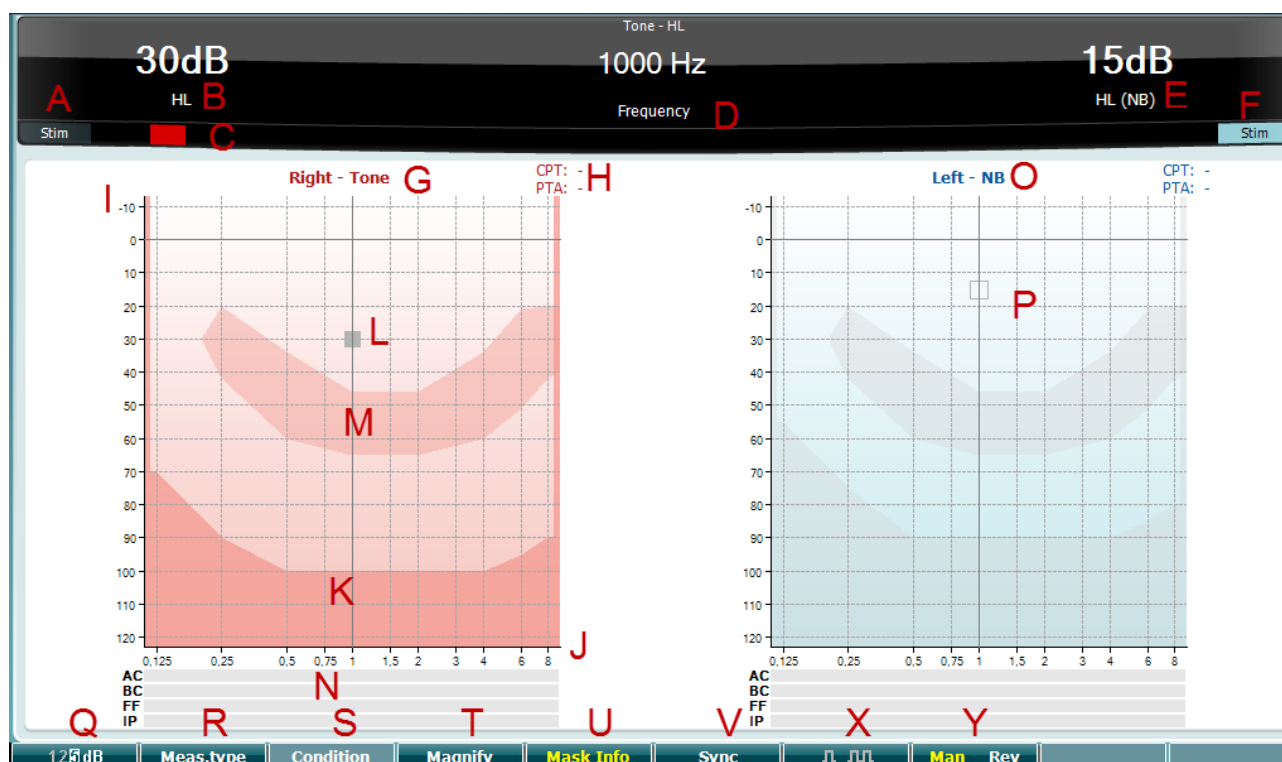



Function Key

Description

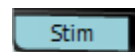

A Use the tone switch (35) to present a sound to the client. The stimulus area will light up when a sound is being presented.



B This visualizes the dial setting of the stimulus intensity which can be changed by rotating the wheel (34).



C This visual indicator is shown when the patient presses the patient response.

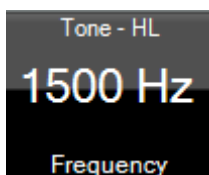

D The measurement type (HL, MCL, UCL or Tinnitus) is shown- as well as the presentation type, e.g., Tone, Stenger, Weber. The test frequency is also shown.



E This visualizes the dial setting of the intensity of channel 2, e.g., masking, which can be changed by rotating the wheel (38).

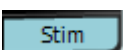

F The stimulus area will light up when a sound is being presented in channel 2, e.g., when masking is active (33).

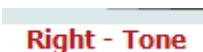

G Indication of ear side and stimulus type for channel 1.

CPT: -
PTA: -

H **CPT** (CPT AMA: Council on Physical Therapy American Medical Association) is a weighed pure tone average for the frequencies 0.5, 1, 2, and 4 kHz according to their importance for speech understanding.

PTA: Indicate the Pure Tone Average (PTA), set up in Tone settings.

Intensity scale

I The intensity scale ranging from -10 to 120 dB HL.

Frequency scale

J The frequency scale ranging from 0,125 kHz to 8 kHz.

Maximum output

K The darker area indicates the maximum intensity range for the selected transducer. The range can be extended by pressing the hard key Ext. range (32).



L The cursor in the audiogram visualizes the currently selected stimulus frequency and intensity.

Speech banan

M The speech banana indicates the area important for speech understanding.

Masking table

N The masking table shows the intensity of the masker for the stored threshold.

Left - NB

O Indication of ear side and stimulus type for channel 2.



P The cursor in the audiogram visualizes the intensity and frequency of the currently selected masking level.











Q Press the “1,2,5 dB” button to toggle the dB step size. The current step size is indicated on the label of this button.

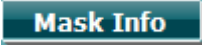
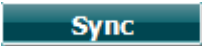

R Hold down the Meas.type button and use the wheel (34/38) to select the threshold type – HL (hearing level), MCL (most comfortable level), UCL (uncomfortable level), Tinnitus (tinnitus level).



	S	Change the condition indication; None, Aided, Binaural, or Aided and Binaural. Only available during free field testing hard key (24).
	T	Switch between magnified top bar and normal-sized top bar.
	U	Show and hide the display of the masking table (N).
	V	Sync allows the masking attenuator to the tone attenuator to be activated. This option is used for e.g., synchronous masking.
	X	Continuous: By default, a continuous tone is presented. Single: Presents the tone with a pre-set length. Multi: Presents the tone pulsing continuously. The length of the single and multi-tone is setup in Common settings - Aud.
	Y	Manual: Manual tone presentation each time tone switch (34) is pressed. Reverse: Continuous tone presentation which will be interrupted each time the tone switch (34) is pressed.
		
		
		
		

3.7.1.1 Stenger

The Stenger test is used when a patient is suspected of feigning a hearing loss and is based on the auditory phenomenon “The Stenger Principle”, that states that only the louder of two similar tones presented to both ears at the same time will be perceived. As a general rule it has been recommended to perform the Stenger test in cases of unilateral hearing loss or significant asymmetry.

The Stenger test screen is selected by pressing Tests and selecting Stenger. The screen is the same as for pure tone audiometry. Please refer to the Tone audiometry test screen above for a description of the test screen. The function buttons Q, T, X, Y are available from the Stenger test screen.

In the Stenger test the signal is presented to both ears when the tone switch is pressed. Use the wheel (34) to adjust the intensity of channel 1 (indicated by cursor L) and wheel (38) to adjust the intensity of channel 2 (indicated by cursor P) prior to pressing the tone switch.



3.7.1.2 ABLB - Fowler

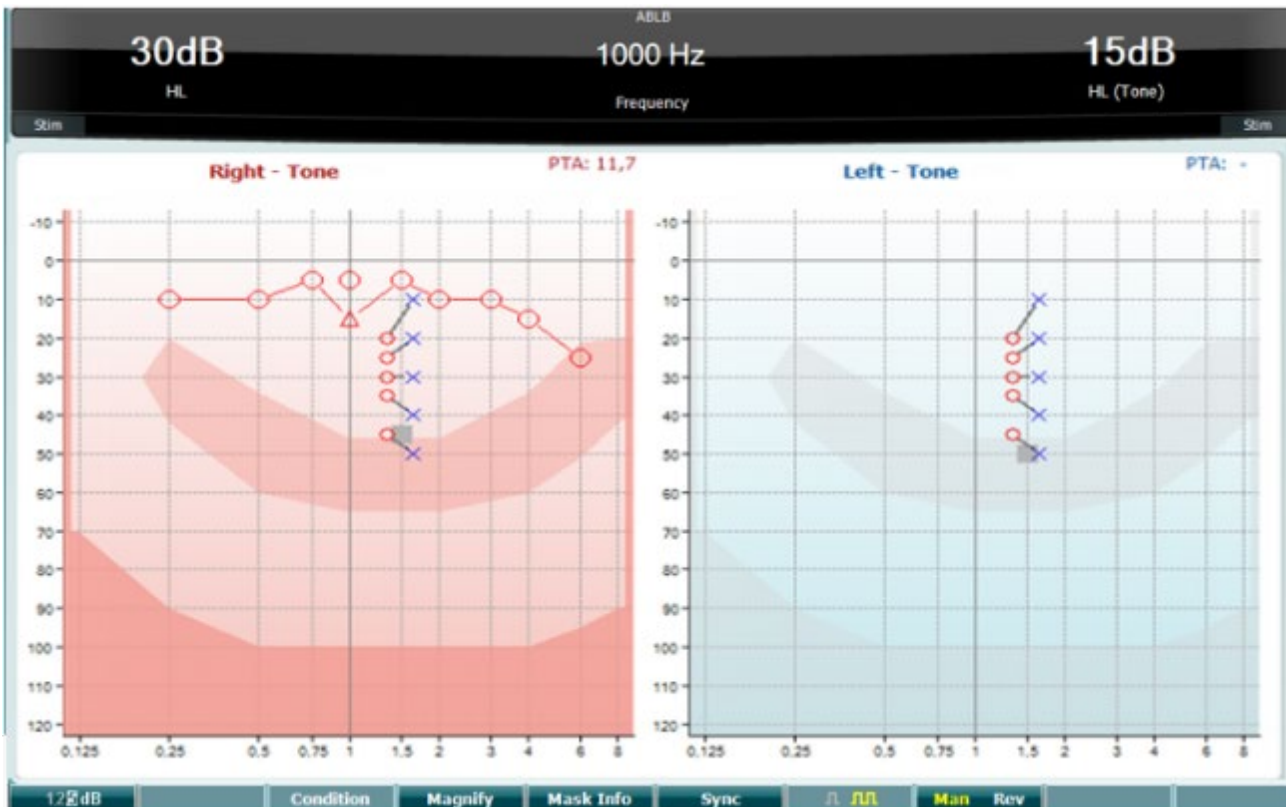

ABLB (Alternate Binaural Loudness Balancing) is a test to detect perceived loudness differences between the ears. The test is designed for people with unilateral hearing loss. It serves as a possible test for recruitment.

The test is performed at frequencies where recruitment is presumed. The same tone is presented alternately to both ears. The intensity is fixed in the impaired ear (20dB above pure tone threshold). The task of the patient is to adjust the level of the better ear until the signal in the two ears is of equal intensity. Note, however, that the test may also be performed by fixing the intensity in the normal hearing ear and having the patient set the tone for the impaired ear.

The function buttons Q, T, U, V, Y are available from the ABLB test screen.

3.7.1.3 Tone in noise (Langenbeck)

For a description of the function keys in Tone in Noise please refer to the pure tone audiometry test screen. The function keys available for the screen are Q, R, T U, X, Y.



3.7.1.4 Speech audiometry

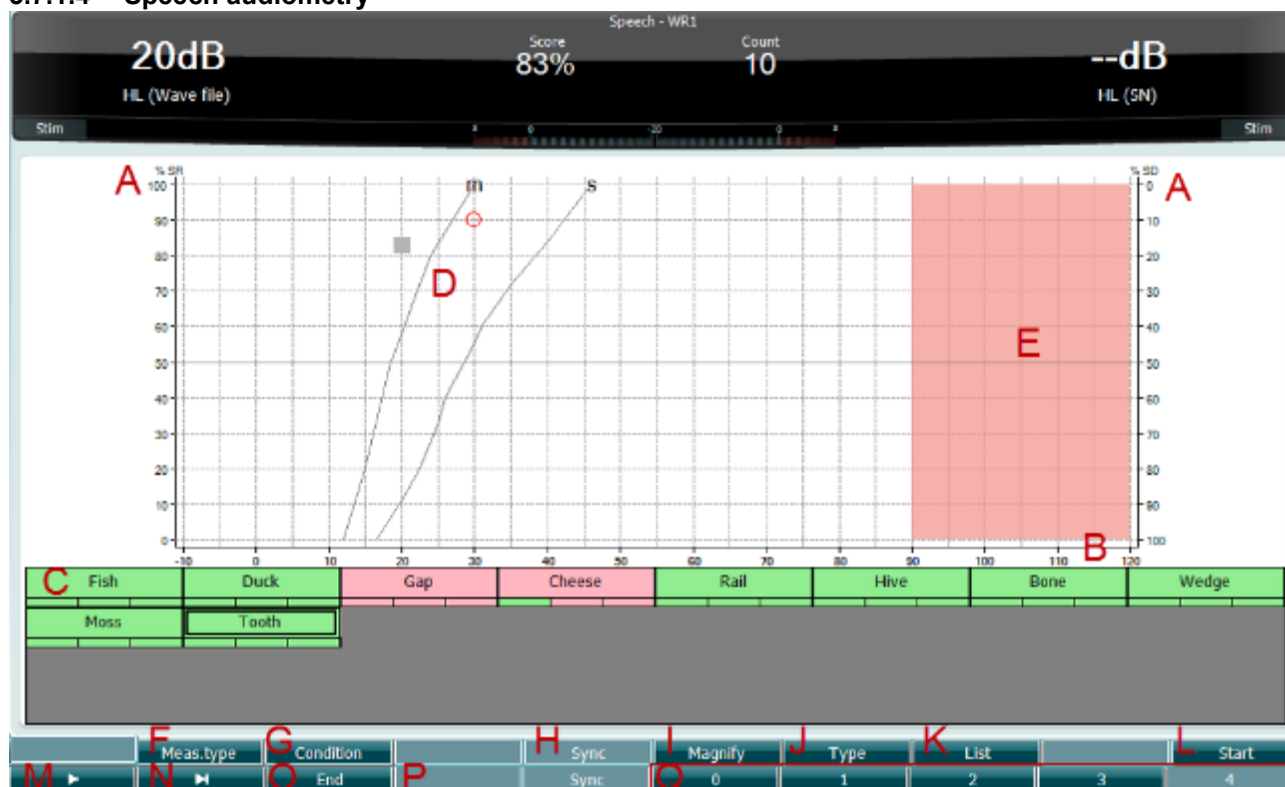

Speech audiometry has the advantage of using a speech signal and is used to quantify the patient's ability to understand everyday communication. It examines the patient's processing ability in relation to the degree and type of their hearing loss which can vary greatly between patients with the same hearing loss configuration.

Speech audiometry can be performed using a number of tests.

SRT (Speech Reception Threshold) refers to the level at which the patient can repeat 50% of the presented words correctly. It serves as a check of the pure tone audiogram, gives an index of hearing sensitivity for speech, and helps determine the starting point for other supra-threshold measures such as WR (Word Recognition).

WR is sometimes also referred to as SDS (Speech Discrimination Scores) and represents the number of words correctly repeated, expressed as a percentage. Use Correct (36) or Incorrect (37) to indicate the word recognition. When doing so, the word recognition score is calculated automatically.

Speech testing can be done via pre-recorded wave files (26), CD input (26) or microphone (27) and can be run in either graphical mode or table mode.



Function Key

SR (Speech Recognition) / **SD** (Speech Discrimination)

Intensity scale

Input list

Phone norm curves

Maximum range

Meas.type

Condition

Sync

Magnify

Type

List

Start

Description

- A **SR** is the speech recognition in 0-100%.
SD is the speech discrimination in 0-100%.
- B The intensity scale ranging from -10 to 120 dB HL.
- C Displays the material for the selected list. When the test is started the word presented is framed.
- D Phone norm curves for the speech material; M for Multi syllabic and S for single syllabic. The phone norm curves can be set in the speech setting – Ph Norms.
- E The area indicates the intensity range that cannot be reached with the selected transducer. Use the hard key Ext. Range (32) to extend the available range.
- F Choose between SRT, MCL and UCL, WR1, WR2 or WR3. Select the required measurement type by using one of the rotary wheels 34/38.



- G The condition under which the speech test is done: None, Aided, Binaural, or Aided & Binaural.
- H Sync allows the masking attenuator to the tone attenuator to be activated. This option is used for e.g., synchronous masking.
- I Switch between magnified top bar and normal-sized top bar.
- J Use the wheels 34/38 to select the different items from the list:

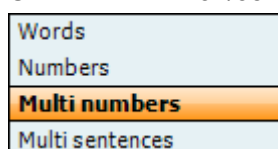

- K Lists can be changed in the “List” option. Use 34/38 to select the different items from the lists.



- L Start playing the wave files.



When the Wavefile test is started, the F-buttons will change to recording mode.



- M Play
- Resume
- Pause



- N Manual forward.
- Pressing shift with this button will allow for manual reverse.



- O Stop playing the wave files.
- When the word-list is completed or another track is to be selected, use the End F-button to leave the recording mode.

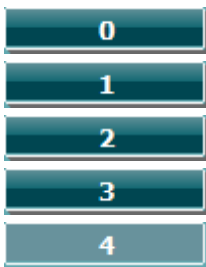

- P Use the numbers during phonetic scoring to indicate the number of phonemes in the word with the correct response.

Speech – Mic

The screen for speech using the microphone is the same as described above. The screen appears by pressing the hard key Mic (27). Hold down the Mic (27) button to adjust the live voice. Adjust the levels until you reach an average of approximately 0 dB VU on the VU meter.

NOTICE

If the speech and calibration signal are not at the same level, this must be manually corrected.

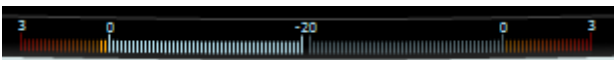

Speech – CD

The screen for speech using an external speech input “speech CD” is the same as described above. The input for speech must be set to CD in the speech settings.

3.7.1.5 Speech – CH2On

This test screen is the same as for speech. When in Speech – Ch2On, the speech material is presented binaurally.

3.7.1.6 Speech in noise

This test screen is the same as for speech. When in Speech in noise, the speech material and speech in noise is presented in the same ear.



3.7.1.7 Weber

The Weber test distinguishes between conductive and sensorineural hearing loss through use of a bone conductor. Use the indications to show where the tone is perceived. If the patient hears the tone better in the poorer ear, then the hearing loss is conductive, and if the tone is heard better in the better ear the hearing loss is sensorineural at the given frequency.

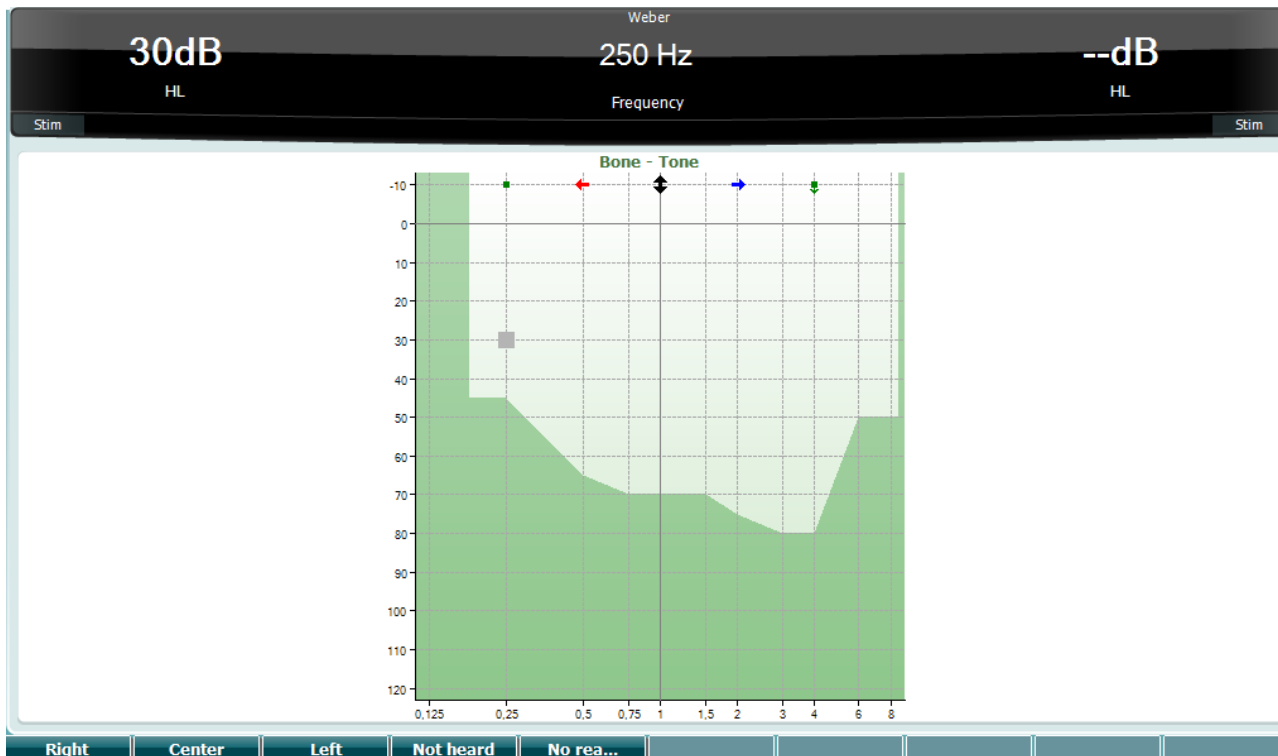

The symbols for Weber correspond to the following soft buttons:

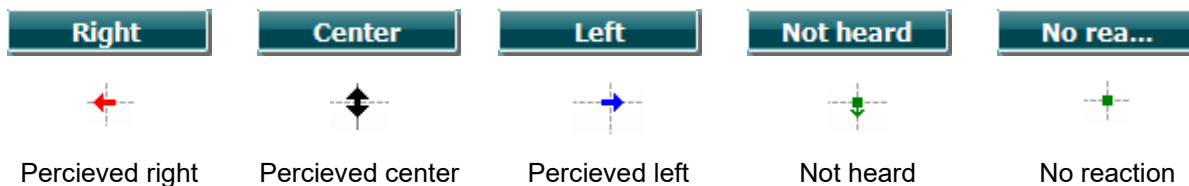



3.7.1.8 Auto: Hughson-Westlake

Hughson-Westlake is an automatic pure tone test procedure. The threshold of hearing is defined as 2 out of 3 (or 3 out of 5) correct responses at threshold level in a 5dB increase and a 10dB decrease test procedure.

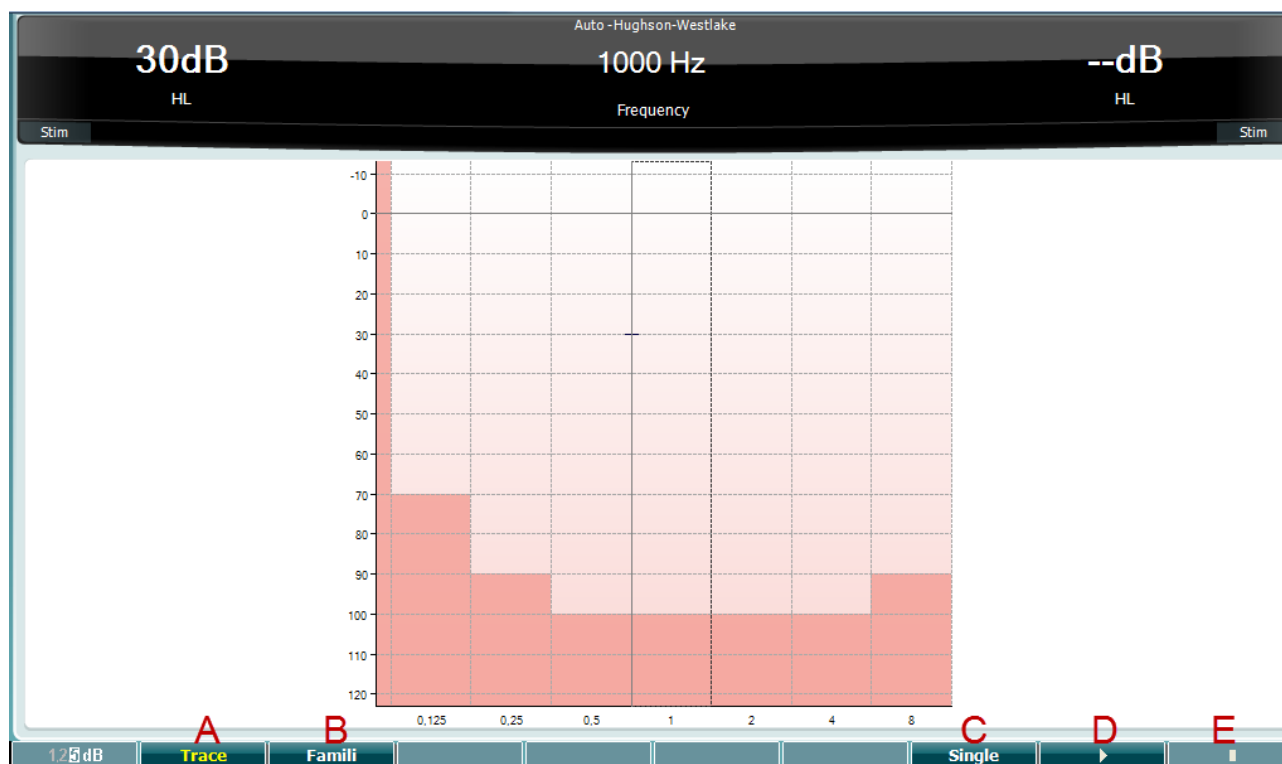

Function Key

Description



A Toggles between showing and hiding the trace.

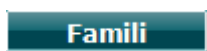

B When activated, the patient can get familiarized with the testing procedure without data being part of the recording.

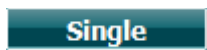

C When pressed the currently selected frequency is tested. The test starts immediately when pressed.



D Press the play button to start the test for all frequencies.



Pause



E Stop



3.7.1.9 QuickSIN test (optional)

The QuickSIN test was developed to provide a quick estimate of SNR loss. A list of six sentences with five key words per sentence is presented in four-talker babble noise. The sentences are presented at pre-recorded signal-to-noise ratios which decrease in 5-dB steps from 25 (very easy) to 0 (extremely difficult). The SNRs used are: 25, 20, 15, 10, 5 and 0, encompassing normal to severely impaired performance in noise. For more information, please refer to Etymotic Research's *QuickSIN™ Speech-in-Noise Test* manual, version 1.3.

SNR loss	Degree of SNR loss	Expected improvement with directional Mic
0-3 dB	Normal / near normal	May hear better than normals in noise
3-7 dB	Mild SNR loss	May hear almost as well as normals in noise
7-15 dB	Moderate SNR loss	Directional microphones help. Consider array mic
> 15 dB	Severe SNR loss	Maximum SNR improvement is needed. Consider FM system

Practice List A (Track 21)		Score
1.	The lake sparkled in the red hot sun.	S/N 25 <input type="text"/>
2.	Tend the sheep while the dog wanders	S/N 20 <input type="text"/>
3.	Take two shares as a fair profit	S/N 15 <input type="text"/>
4.	North winds bring colds and fevers	S/N 10 <input type="text"/>
5.	A sash of gold silk will trim her dress	S/N 5 <input type="text"/>
6.	Fake stones shine but cost little	S/N 0 <input type="text"/>
25.5 - TOTAL = <input type="text"/>		SNR loss <input type="text"/>
		Total <input type="text"/>

Function Key

Description



A CH2On enables channel 2 to be adjusted independently of channel 1. This should only be done for the lists 24-35.



B Different lists can be changed in the "List" option. Use wheel 34/38 to select the different items in the lists.



C Start QuickSIN test.



Stop QuickSIN test.



3.7.1.10 SISI (short increment sensitivity index)

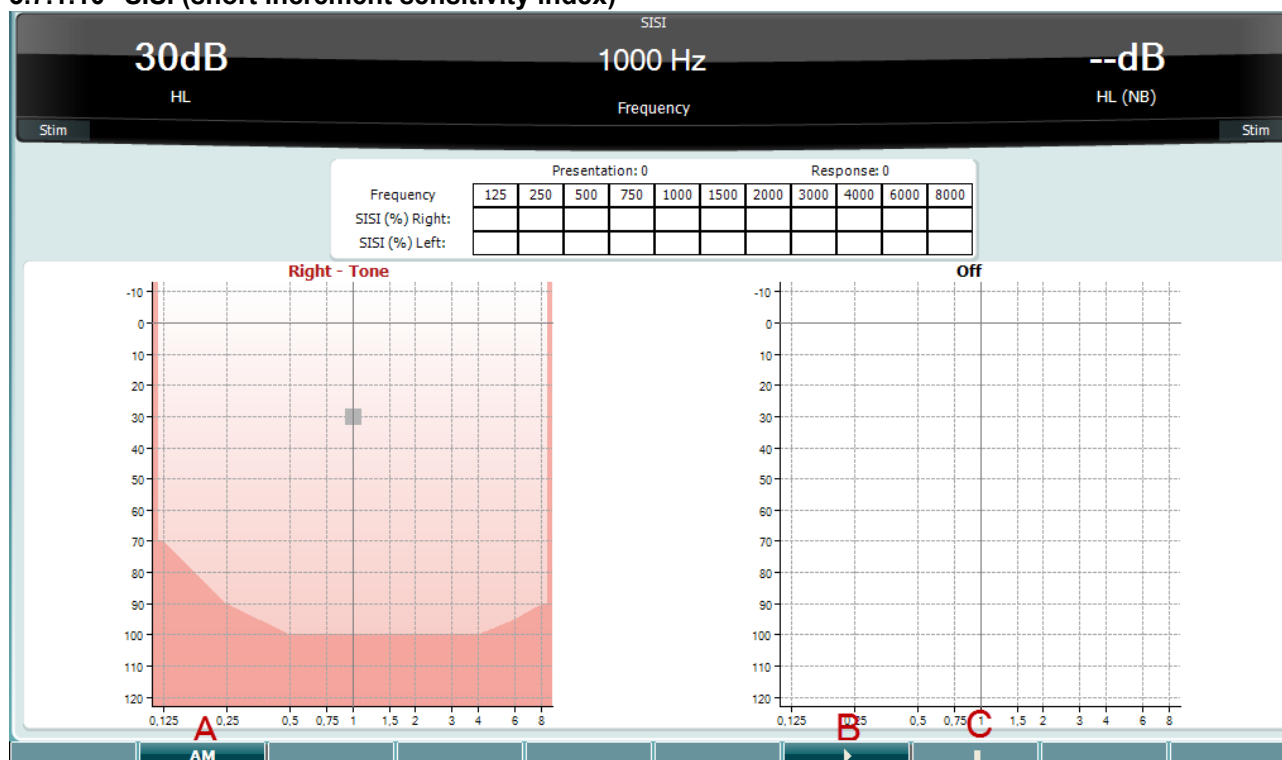

SISI is designed to test the ability to recognize a 1dB increase in intensity during a series of bursts of pure tones presented 20 dB above the pure tone threshold for the test frequency. It can be used to differentiate between cochlear and retro cochlear disorders, as a patient with a cochlear disorder will be able to perceive the increments of 1 dB, whereas a patient with a retro cochlear disorder will not. 20 measures must be obtained in order to have the SISI threshold shown at the given frequency.

Function Key

Description



A Amplitude Modulation (0, 1(SISI), 2, 5).



B Start SISI test.



Pause SISI test.



C Stop SISI test.



3.8 Operating in sync mode (only with the Diagnostic Suite)

NOTICE

3.8.1 PC power configuration

Allowing the PC to go into sleep mode or hibernation may cause the Suite to crash when the PC wakes up again. From the Start menu of your operating system, go to the **Control Panel | Power Options** to change these settings.

3.8.2 Starting from OtoAccess®

For instructions about working with the OtoAccess® database, please see the operation manual for OtoAccess®.

3.8.3 Starting from Noah 4

To start the Diagnostic Suite from Noah 4:

1. Open Noah 4.
2. Search for and select the patient you want to work with.
3. If the patient is not yet listed:
 - Click the **Add a New Patient** icon
 - Fill in the required fields and click **OK**
4. Click on the **Diagnostic Suite module** icon at the top of the screen.

For further instructions about working with the database, please see the operation manual for Noah 4.

3.8.4 Crash report

In the event of the Diagnostic Suite crashing the details can be logged by the system. The Crash Report window will appear on the test screen (as shown below). The crash report provides information to Interacoustics about the error message. Extra information can be added by the user outlining what they were doing before the crash occurred in order to assist in fixing the problem. A screen shot of the software can also be sent.

The “I agree to the Exclusion of Liability” check box must be checked before the crash report can be sent via the internet. For those users without an internet connection, the crash report can be saved to an external drive so it can then be sent from another computer with an internet connection.

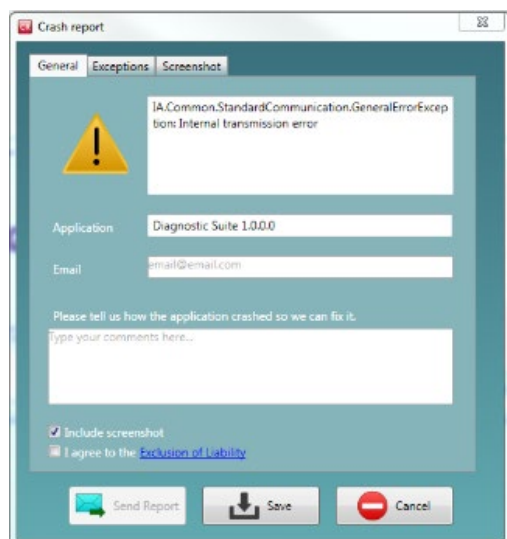



3.8.5 Instrument setup

Select Menu | Setup | Suite setup... to open general suite settings.

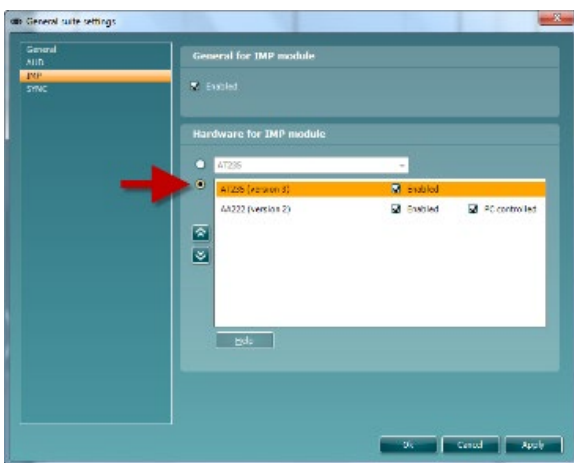
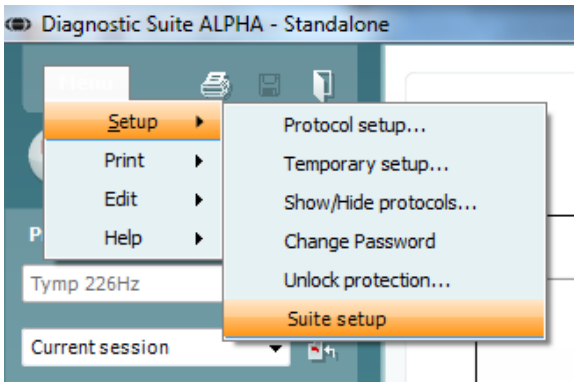

Important: Both at the AUD module and the IMP module, please be sure to select the “AA222 (version 2)” and not “AA222”, which refers to the old version.



3.9 Using sync mode

Sync mode allows for a one-click data transfer. When pressing Save Session on the instrument, the session will automatically be transferred to the Diagnostic Suite. Start the suite with device connected.

3.9.1 Using IMP sync

The following operations are available on the IMP tab of the Diagnostic Suite:

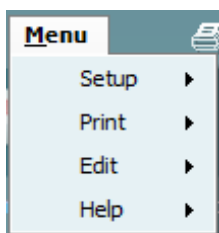
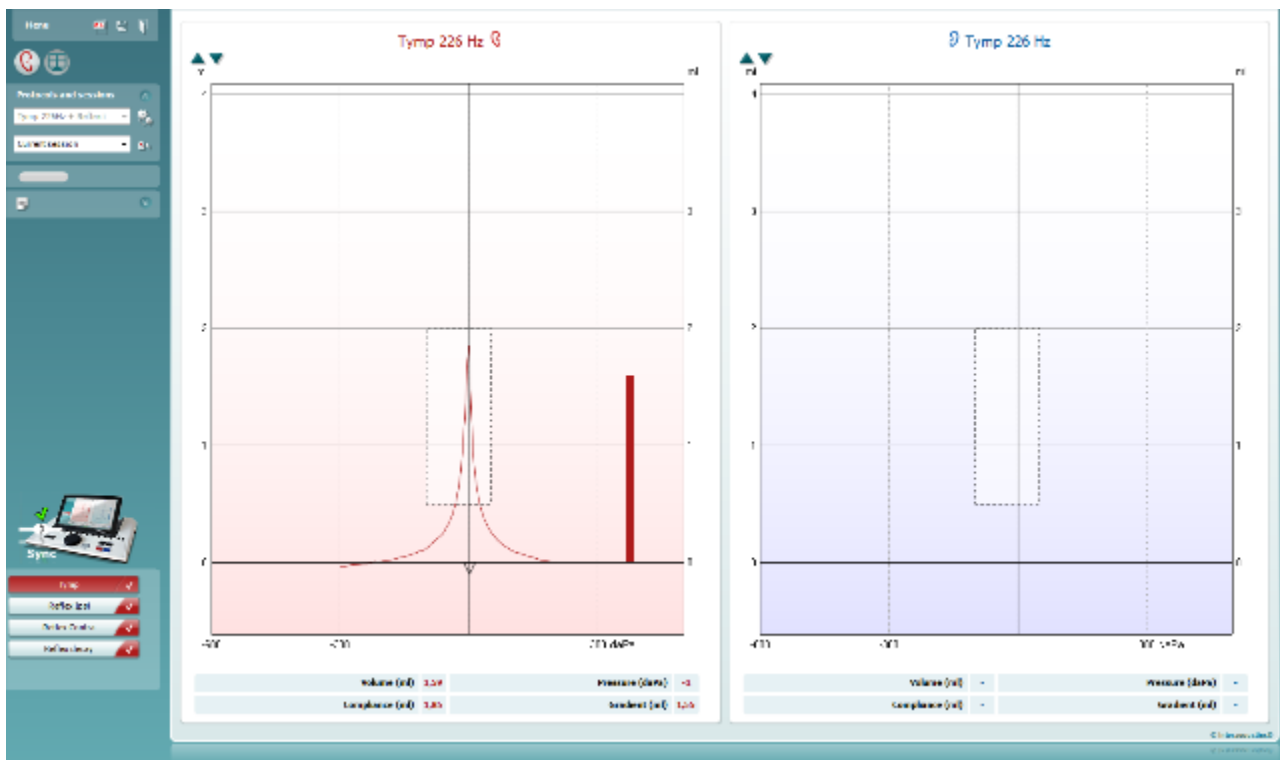

Menu provides access to Setup, Print, Edit and Help (refer to the Additional Information document for more details about the menu items).

Change of language:

Menu | Setup | Suite Setup takes you to a window from where you can change the language.

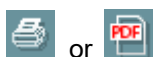

Print allows for printing the onscreen results directly to your default printer or to a pdf file. You will be prompted to select a print template if the protocol does not have one linked to it (refer to the Additional Information document for more details about the print wizard).



Save & New Session saves the current session in Noah or OtoAccess® (or to a commonly used XML file when running in standalone mode) and opens a new session.



Save & Exit saves the current session in Noah or OtoAccess® (or to a commonly used XML file when running in standalone mode) and exits the Suite.



Toggle Ear changes from right to left ear and vice versa.

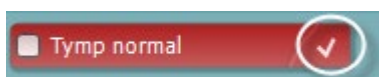
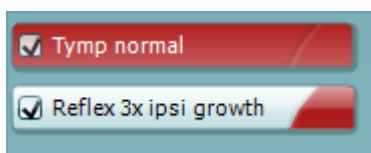
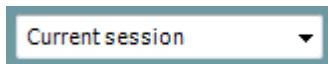

List of Defined Protocols allows viewing which protocol was used for historic sessions.

Temporary setup allows viewing the used settings for historic sessions.

List of historical sessions accesses historical sessions for review, or the **Current Session**.

Go to current session takes you back to the current session.

Report editor button opens a separate window for adding and saving notes to the current session.

The **hardware indication picture** indicates whether the hardware is connected. **Simulation mode** is indicated when operating the software without hardware.

The **protocol listing** shows all tests that are part of the used protocol. The test that is displayed in the test screen area is highlighted blue or red, depending on the chosen ear.

If more tests than can fit in the window are included in the protocol, a scrollbar will be visible.

A **white checkmark** indicates that (at least some) data for this test was saved.



3.9.2 Using AUD sync

The following operations are available on the AUD tab of the Diagnostic Suite:

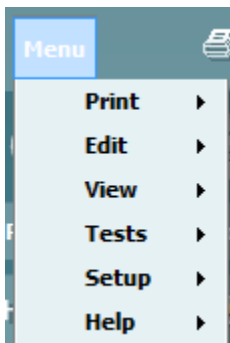
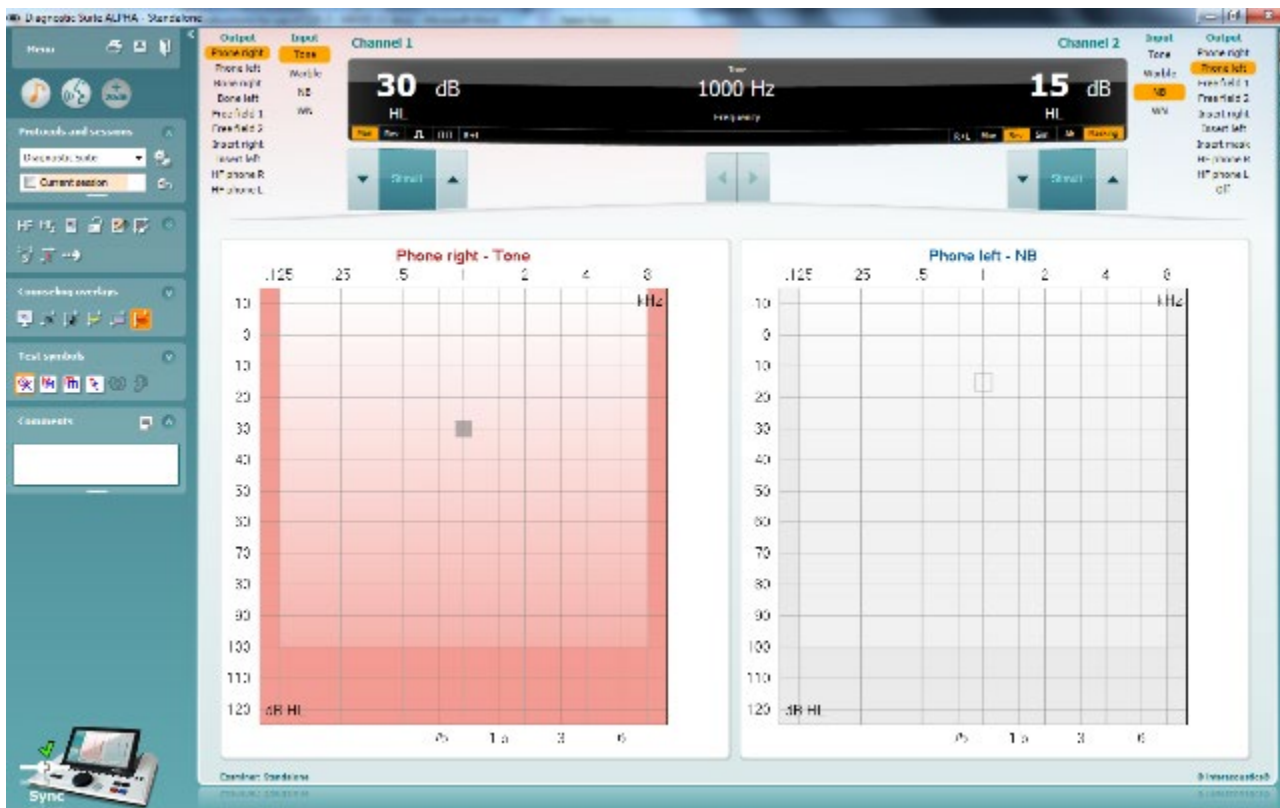

Menu provides access to Print, Edit, View, Tests, Setup and Help (refer to the Additional Information document for more details about the menu items).

Change of language:

Menu | Setup | Language takes you to a window from where you can change the language.



Print allows for printing the onscreen results directly to your default printer or to a pdf file. You will be prompted to select a print template if the protocol does not have one linked to it. Refer to the Instructions for Use for Diagnostic Suite for more details about the print wizard.



Save & New Session saves the current session in Noah or OtoAccess® (or to a commonly used XML file when running in standalone mode) and opens a new session.



Save & Exit saves the current session in Noah or OtoAccess® (or to a commonly used XML file when running in standalone mode) and exits the Suite.



Tone test shows the tone audiogram.



Speech test shows the speech graph or speech table.

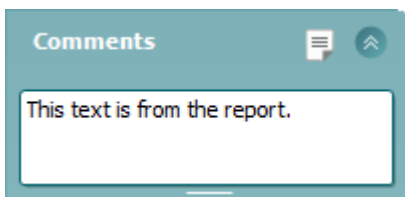
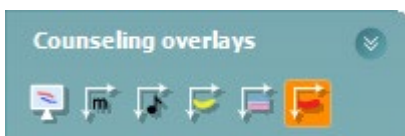
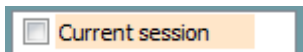
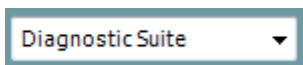

Extended range allows opening the highest intensities of the currently selected transducers.

List of Defined Protocols allows viewing which protocol was used for historical sessions.

Temporary setup allows viewing the used settings for historical sessions.

List of historical sessions accesses historical sessions for review, or the **Current Session**.

Go to current session takes you back to the current session.

Single audiogram showing both right and left data in a single audiogram.

Synchronize channels locking channel 2 to channel 1 so that the intensity difference between the channels remains constant.

Edit mode allows entering an audiogram by clicking with the mouse.

Mouse controlled audiometry allowing stimulus presentation and storage by mouse control in the audiogram.

dB step size allows toggling between 1, 2 and 5 dB step size.

Hide unmasked threshold allows showing or hiding unmasked thresholds for which a masked threshold exists.

The **counseling overlays** can be activated on a separate **patient monitor**. Phonemes, sound examples, speech banana, a severity indication and maximum testable values are available as overlays.

Report editor button opens a separate window for adding and saving notes to the current session. These notes can also be read or typed in the white space.

The hardware indication picture indicates whether the hardware is connected. **Simulation mode** is indicated when operating the software without hardware.



3.9.3 Sync mode

If there are several sessions stored on the AA222 (under one or more patients) that should be transferred to the PC then the Sync tab can be used. The screen shot below shows the Diagnostic Suite with the SYNC tab open (underneath the AUD and IMP tabs in the upper right corner).



The SYNC tab provides the following options:



Client upload is used for uploading clients from the database (Noah or OtoAccess®) to the AA222. The internal AA222 memory can hold up to 500 clients and 50,000 sessions.

Session download is used to download (audiogram and/or tympanometry) sessions from the AA222 memory to Noah, OtoAccess® or XML (the latter when running the Diagnostic suite without a database).

3.9.4 Client upload

The following screen shot shows the client upload screen:



- On the left hand side, it is possible to search for the client in the database in order to transfer to the database using different search criteria. Use the “Add” button to transfer (upload) the client from the database to the internal AA222 memory. The internal AA222 memory can hold up to 500 clients and 50,000 sessions.
- On the right hand side, the clients currently stored in the internal AA222 memory (hardware) is shown. It is possible to remove all clients or individual clients using the “Remove all” or “Remove” buttons.



3.9.5 Session download

The following screen shot shows the session download screen:

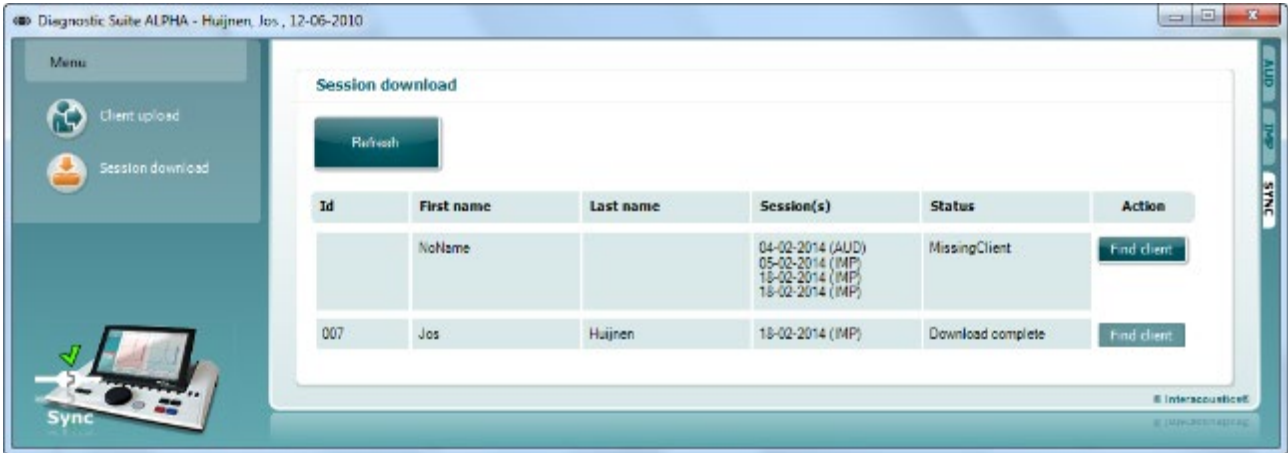

When pressing the “Find client” button, a window (see below) pops up where the corresponding client can be found. Press the “Save” button to start downloading the sessions of this client to the database.

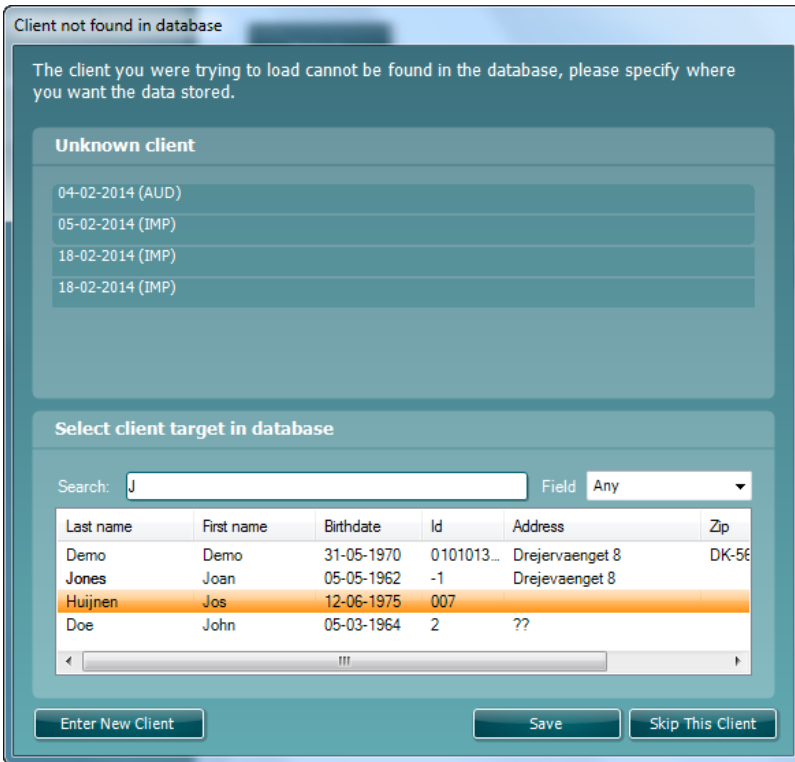



4 Maintenance

4.1 General maintenance procedures

Routine checking (subjective tests)

It is recommended that routine check procedures are carried out weekly in full on all equipment in use. Checklist 1-9 outlined below should be carried out on the equipment on each day of use.

General

The purpose of routine checking is to ensure that the equipment is working properly, that its calibration has not significantly changed, and that its transducers and connections are free from any defect that might adversely affect the test result. The checking procedures should be carried out with the audiometer set up in its usual working situation. The most important elements in daily performance checks are the subjective tests and these tests can only be successfully carried out by an operator with unimpaired and preferably predetermined levels of hearing. If a booth or separate test room is used, the equipment should be checked as installed; an assistant may be required in order to carry out the procedures. The checks will then cover the inter-connections between the audiometer and the equipment in the booth, and all connecting leads, plugs, and socket connections at the junction box (sound room wall) should be examined as potential sources of intermittency or incorrect connection. The ambient noise conditions during the tests should not be substantially worse than those encountered when the equipment is in use.

- 1) Clean and examine the audiometer and all accessories.
- 2) Check earphone cushions, plugs, main leads, and accessory leads for signs of wear or damage. Damaged or badly worn parts should be replaced.
- 3) Switch on equipment and leave for the recommended warm-up time.
- 4) Check that earphone and bone vibrator serial numbers are correct for use with the audiometer.
- 5) Check that audiometer output is approximately correct on both air and bone conduction by conducting a simplified audiogram on a known test subject with known hearing; check for any change.
- 6) Check at high level (for example hearing levels of 60dB on air conduction and 40 dB on bone conduction) on all appropriate functions (and on both earphones) at all frequencies used; listen for proper functioning, absence of distortion, freedom from clicks, etc.
- 7) Check all earphones (including masking transducer) and the bone vibrator for absence of distortion and intermittency; check plugs and leads for intermittency.
- 8) Check that all switch knobs are secure and that indicators work correctly.
- 9) Check that the subject's signal system operates correctly.
- 10) Listen at low levels for any sign of noise, hum, or unwanted sounds (break-through arising when a signal is introduced in another channel) or for any change in tone quality as masking is introduced.
- 11) Check that attenuators do attenuate the signals over their full range and that attenuators which are intended to be operated while a tone is being delivered are free from electrical or mechanical noise.
- 12) Check that controls operate silently and that no noise radiated from the audiometer is audible at the subject's position.
- 13) Check subject communication speech circuits, if appropriate, applying procedures similar to those used for pure-tone function.
- 14) Check tension of headset headband and bone vibrator headband. Ensure that swivel joints are free to return without being excessively slack.
- 15) Check headbands and swivel joints on noise-excluding headsets for signs of wear strain or metal fatigue.



CAUTION

- Before cleaning always switch off and disconnect from the power supply
- Follow local best practice and safety guidelines if available
- Use a soft cloth lightly dampened with cleaning solution to clean all exposed surfaces
- Do not allow liquid to come in contact with the metal parts inside the earphones / headphones
- Do not autoclave, sterilize, or immerse the instrument or accessory in any fluid
- Do not use hard or pointed objects to clean any part of the instrument or accessory
- Do not let parts that have been in contact with fluids dry before cleaning
- Rubber ear-tips or foam ear-tips are single use components

Recommended cleaning and disinfection solutions

- Warm water with mild, nonabrasive cleaning solution (soap)
- 70% isopropyl alcohol

Procedure

- Clean the instrument by wiping outer case with a lint free cloth lightly dampened in cleaning solution
- Clean cushions and patient hand switch and other parts with a lint free cloth lightly dampened in cleaning solution
- Make sure to not get moisture in the speaker portion of the earphones and similar parts



To maintain electrical safety during the lifetime of the instrument, a safety check must be made regularly according to IEC 60601-1, Class 1, Type B. E.g., when yearly calibration is done.



4.2 Cleaning the probe tip

Diagnostic probe

Clinical probe

Step 1: Unscrew the probe cap and remove the probe tip.

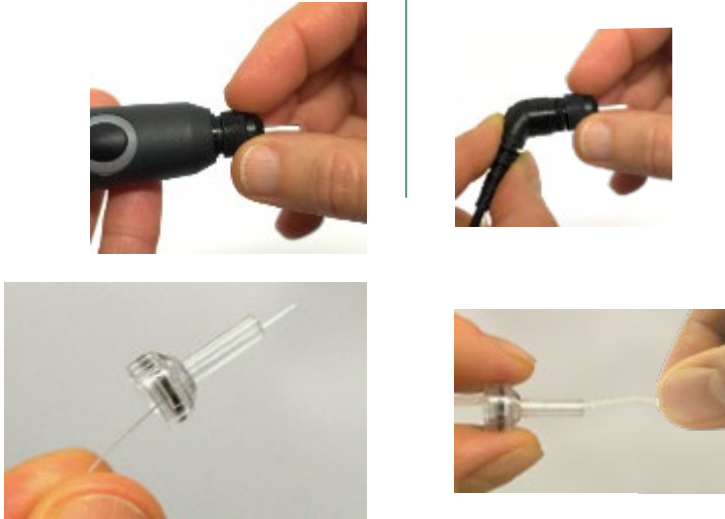

Step 2: Thread the stiff end of the cleaning brush into one of the tubes from inside. Pull the cleaning floss completely through the probe tip tube. Clean each of the



Step 3: Replace the cleaned tip.

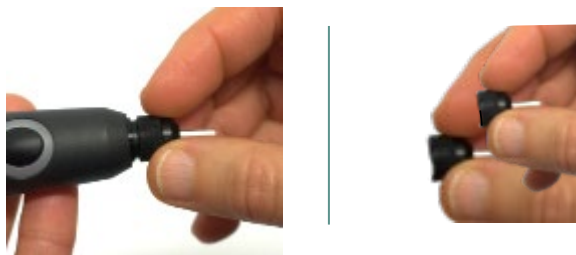

Step 4: Assemble the probe again.

Notice:

Only insert the cleaning brush from inside out, this will ensure that the dirt is pushed out of the probe instead of into the probe and as well protect the gasket from being damaged. Never clean inside the probe holes.

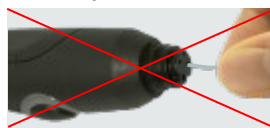



4.3 Repair

Interacoustics is only considered to be responsible for the validity of the CE marking, effects on safety, reliability, and performance of the equipment if:

1. assembly operations, extensions, readjustments, modifications, or repairs are carried out by authorized persons
2. a 1 year service interval is maintained
3. the electrical installation of the relevant room complies with the appropriate requirements, and
4. the equipment is used by authorized personnel in accordance with the documentation supplied by Interacoustics

The customer shall reach out to the local distributor to determine the service/repair possibilities including onsite service/repair. It is important that the customer (through local distributor) fills out the **RETURN REPORT** every time when the component/product is sent for service/repair to Interacoustics.

4.4 Warranty

Interacoustics guarantees that:

- The AA222 is free from defects in material and workmanship under normal use and service for a period of 24 months from the date of delivery by Interacoustics to the first purchaser
- Accessories are free from defects in material and workmanship under normal use and service for a period of ninety (90) days from the date of delivery by Interacoustics to the first purchaser

If any product requires service during the applicable warranty period, the purchaser should communicate directly with the local Interacoustics service center to determine the appropriate repair facility. Repair or replacement will be carried out at Interacoustics' expense, subject to the terms of this warranty. The product requiring service should be returned promptly, properly packed, and postage prepaid. Loss or damage in return shipment to Interacoustics shall be at purchaser's risk.

In no event shall Interacoustics be liable for any incidental, indirect or consequential damages in connection with the purchase or use of any Interacoustics product.

This warranty shall apply solely to the original purchaser. This warranty shall not apply to any subsequent owner or holder of the product. Furthermore, this warranty shall not apply to, and Interacoustics shall not be responsible for, any loss arising in connection with the purchase or use of any Interacoustics product that has been:

- repaired by anyone other than an authorized Interacoustics service representative
- altered in any way, so that it, in Interacoustics' opinion, affects its stability or reliability
- subject to misuse or negligence or accident, or that has had the serial or lot number altered, defaced, or removed; or
- improperly maintained or used in any manner other than in accordance with the instructions provided by Interacoustics

This warranty is in lieu of all other warranties, expressed or implied, and of all other obligations or liabilities of Interacoustics. Interacoustics does not give or grant, directly or indirectly, the authority to any representative or other person to assume on behalf of Interacoustics any other liability in connection with the sale of Interacoustics products.

INTERACOUSTICS DISCLAIMS ALL OTHER WARRANTIES, EXPRESSED OR IMPLIED, INCLUDING ANY WARRANTY OF MERCHANTABILITY OR FOR FUNCTION OF FITNESS FOR A PARTICULAR PURPOSE OR APPLICATION.



4.5 Periodic calibration

Minimum periodic calibration requirements:

Minimum calibration interval of once (annually) per 12-month period.

Records of all calibrations should be kept on file.

Recalibration should be performed after:

1. A specified time period has elapsed (12-month period maximum, annually).
2. When an audiometer or transducer has had a shock, vibration, malfunction, or a repair or part replacement has been performed which potentially may have put the audiometer out of calibration.
3. Whenever the user suspects patient results to be inaccurate.

Annual calibration

It is recommended that an annual calibration be performed by a trained technician/a skilled laboratory, knowledgeable and up to date in the relevant requirements of ANSI/ASA and/or IEC and the device specifications. The calibration procedure must validate all relevant performance requirements given in ANSI/ASA and/or IEC.



5 Technical specifications

General		
Medical CE-mark:	The CE-mark in combination with MD symbol indicates that Interacoustics A/S meets the requirements of the Medical Device Regulation (EU) 2017/745. Approval of the quality system is made by TÜV – identification no. 0123.	
Standards:	Safety:	IEC 60601-1, Class I, Type B applied parts
	EMC:	IEC 60601-1-2
	Impedance:	IEC 60645-5 (2004)/ANSI S3.39 (2012), Type 1
	Audiometer:	Tone Audiometer: IEC 60645 -1 (2012), ANSI S3.6 (2010), Type 2 Speech Audiometer: IEC 60645-2 (1997)/ANSI S3.6 (2010) type B or B-E. Auto threshold tests: ISO 8253-1 (2010)
Operation environment:	Temperature:	15 – 35 °C
	Relative Humidity:	30 – 90%
	Ambient Pressure:	98kPa – 104kPa
	Warm-up Time:	1 minute
Display	10 inch high resolution color display 1024x600	
Transport & Storage:	Storage Temperature:	0°C – 50°C
	Transport Temperature:	-20 – 50 °C
	Rel. Humidity:	10 – 95%
Internal storage	500 clients and 50.000 sessions	
Internal Battery	CR2032 3V, 230mAh, Li. Not serviceable by user.	
PC control:	USB:	Input/output for computer communication. AA222 can be fully operated from a PC. The measurements can then be followed on the PC screen. Data can be transferred to Diagnostic Suite and stored in OtoAccess® or Noah.
Thermal printer (Optional):	Type: MPT-III	Thermal MPT-III printer with recording paper in rolls. HP Officejet Pro 251dw, HP LaserJet Pro 400 color M451nw, HP Color Laser Jet pro M252n, HP Color Laser Jet Enterprise M553. Print on command via USB
Power supply 	UES65-240250SPA3	Use only specified power supply unit type Input: 100-240VAC 50-60Hz, 2.0 A Output: 24.0 VDC
Dimensions	H x W x L	9 x 33 x 44 cm 3.5 x 13 x 17.3 inches
AA222 Weight	3.1 kg / 6.8 lb	

Impedance Measuring System		
Probe tone:	Frequency: Level:	226 Hz, 678 Hz, 800 Hz, 1000 Hz; pure tones; ±1% 85 dB SPL (≈ 69 dB HL) ±1.5 dB
Air pressure:	Control: Indicator: Range: Pressure limitation: Pump speed:	Automatic. Measured value is displayed on the graphical display. -600 to +400 daPa. ±5% -750 daPa and +550 daPa. Automatic, Fast 300 daPa/s, Medium 200 daPa/s, Slow 100 daPa/s, Very slow 50 daPa/s.
Compliance:	Range:	0.1 to 8.0 ml at 226 Hz probe tone (Ear volume: 0.1 to 8.0 ml) and 0.1 to 15 mmho at 678, 800 and 1000 Hz probe tone. All ±5%
Test types:	Tympanometry	Automatic, where the start and stop pressure can be user-programmed in the setup function. Manual control of all functions.



	Eustachian tube function 1 - Non perforated eardrum	Williams test
	Eustachian tube function 2 - Perforated eardrum	Toynbee test
	Eustachian tube function 3 - Patulous Eustachian tube	Continuous sensitive impedance measurement
Reflex Functions		
Signal sources:	Tone - Contra, Reflex: THD:	250, 500, 1000, 2000, 3000, 4000, 6000, 8000 Hz, Wide Band, High and Low pass. Less than 5 until 110 dB, 5 % above 110 dB (supra-aural headphones), less than 5 % until 110 dB, 10 % above 110 dB (insert earphones or probe).
	Tone - Ipsi, Reflex:	500, 1000, 2000, 3000, 4000 Hz wide band, high and low pass.
	NB noise – Contra, Reflex	250, 500, 1000, 2000, 3000, 4000, 6000, 8000 Hz
	NB noise – Ipsi, Reflex	1000, 2000, 3000, 4000 Hz
	Stimulus duration:	750 ms
	Reflex Acceptance	Adjustable between 2 % and 6 %, or 0.05 – 0.15 ml change of ear canal volume.
	Intervals	Down to 1 dB step size.
	Intensity max	90, 100, 120 dB HL.
Outputs:	Contra Earphone:	TDH39 earphone, DD45 earphone and/or EARTone 3A insert, IP30 for Reflex measurements.
	Ipsi Earphone:	Probe earphone incorporated in the probe system for Reflex measurements.
	Probe connection	Connection of the electrical and air system to the probe.
Test types:	Manual Reflex	Manual control of all functions.
	Automated Reflex	Single intensities Reflex growth
	Reflex Decay	Automatic, 10 dB above threshold and manually controlled with stimulus durations of 10 s.
	Reflex latency	Automated, first 300 ms from stimulus start.

Audiometry measure system		
Air Conduction	DD45: TDH39: HDA300: HDA280: DD65 v2 E.A.R Tone 3A/5A: IP 30:	PTB/DTU report 2009 ISO 389-1 1998, ANSI S3.6-2010 PTB report PTB 1.61 – 4064893/13 PTB report 2004 PTB 1.61-4091606 2018 & AAU 2018 ISO 389-2 1994, ANSI S3.6-2010 ISO 389-2 1994, ANSI S3.6-2010 DES-2361
Bone Conduction	B71: B81: Placement:	ISO 389-3 1994, ANSI S3.6-2010 ISO 389-3 1994, ANSI S3.6-2010 Mastoid
Free Field		ISO 389-7 2005, ANSI S3.6-2010
Effective masking		ISO 389-4 1994, ANSI S3.6-2010



Transducers	DD45 TDH39 HDA300 HDA280 DD65 v2 B71 B81 E.A.R Tone 3A/5A IP30	Headband Static Force 4.5N ±0.5N Headband Static Force 4.5N ±0.5N Headband Static Force 8.8N ±0.5N Headband Static Force 4.5N ±0.5N Headband Static Force 10 ±0.5N Headband Static Force 5.4N ±0.5N Headband Static Force 5.4N ±0.5N
Patient Response switch	One handheld push button	
Patient communication	Talk Forward (TF) and Talk Back (TB)	
Monitor	Output through built-in speaker or through external earphone or speaker.	
Special tests/test battery	SISI, ABLB, Stenger, Stenger Speech, Langenbeck (tone in noise), 2 channel speech, Auto threshold Auto threshold tests: Available time for patient to respond: Same as tone presentation Increment of hearing level: 5dB.	
Tone	125-8000Hz. Resolution 1/2-1/24 octave.	
Warble Tone	1-10 Hz sine +/- 5% modulation	
Wave file	44100Hz sampling, 16 bits, 2 channels	
Masking	Automatic selection of narrow band noise (or white noise) for tone presentation and speech noise for speech presentation. Narrow band noise: IEC 60645-1:2001, 5/12 Octave filter with the same center frequency resolution as pure Tone. White noise: 80-20000Hz measured with constant bandwidth Speech Noise: IEC 60645-2:1993 125-6000Hz falling 12dB/octave above 1KHz +/-5dB	
Presentation	Manual or Reverse. Single or multiple pulses. Auto testing: duration 1-2 s adjusted in 0.1 s intervals	
Intensity	Check the accompanying Appendix. Available Intensity Steps is 1, 2 or 5dB Extended range function: If not activated, the Air Conduction output will be limited to 20 dB below maximum output.	
Frequency range	125Hz to 8kHz 125Hz, 250Hz, 750Hz, 1500Hz and 8kHz may freely be deselected	



Speech	Frequency Response:					
	<i>(Typical)</i>	<i>Frequency</i>	<i>Linear (dB)</i>		<i>Freqv (dB)</i>	
		<i>(Hz)</i>	<i>Ext sign¹</i>	<i>Int.</i>	<i>Ext sign¹</i>	<i>Int.</i>
			<i>Sign²</i>		<i>Sign²</i>	
	<i>TDH39</i>	125-250	+0/-2	+0/-2	+0/-8	+0/-8
	<i>(IEC 60318-3</i>	250-4000	+2/-2	+2/-1	+2/-2	+2/-2
<i>Coupler)</i>	4000- 6300	+1/-0	+1/-0	+1/-0	+1/-0	
<i>DD65v2</i>	125-250	+0/-2	+1/-0	+0/-	+0/-7	
<i>(IEC 60645-1</i>	250-4000	+1/-1	+1/-1	+2/-2	+2/-3	
<i>Coupler)</i>	4000- 6300	+0/-2	+0/-2	+1/-1	+1/-1	
<i>E.A.R Tone 3A</i>	250-4000	+2/-3	+4/-1	(Non linear)		
<i>(IEC 60318-5</i>						
<i>Coupler)</i>						
<i>IP 30</i>	250-4000	+2/-3	+4/-1	(Non linear)		
<i>(IEC 60318-5</i>						
<i>Coupler)</i>						
<i>B71/B81 Bone</i>	250-4000	+12/-	+12/-	(Non linear)		
<i>Conductor</i>		12	12			
<i>(IEC 60318-6</i>						
<i>Coupler)</i>						
	2% THD at 1000 Hz max output +9 dB (increasing at lower frequency) Level range: -10 to 50 dB HL, overall THD <6% 1. Ext. sign: CD input					2. Int. sign: Wave files
External signal	Speech replaying equipment connected to the CD input must have a signal-to-noise ratio of 45 dB or higher. The speech material used must include a calibration signal suitable for adjusting the input to 0 dBVU.					
Microphone (Live speech)	The included headset is used for live speech presentation. The monitor headset is a boom type microphone placed near the mouth of the operator. Before live speech is performed the microphone gain must be adjusted to 0 VU.					
Free Field	<u>Power amplifier and loudspeakers</u> With an input of 7 Vrms - Amplifier and loudspeakers must be able to create a Sound Pressure Level of 100 dB in a distance of 1 meter - and meet the following requirements:					
	Frequency Response		Total Harmonic Distortion			
	125-250 Hz	+0/-10 dB	80 dB SPL	< 3%		
	250-4000 Hz	±3 dB	100 dB SPL	< 10%		
	4000-6300 Hz	±5 dB				
Signal Indicator (VU)	Time weighting:		300mS			
	Dynamic range:		23dB			
	Rectifier characteristics:		RMS			
	Selectable inputs are provided with an attenuator by which the level can be adjusted to the indicator reference position (0dB).					



Data Connections (sockets)	1 x USB A (compatible with USB 1.1 and later) 1 x USB B (compatible with USB 1.1 and later) 1 x LAN 1 x HDMI (VGA 640x480)	
External keyboard	Standard keyboard (for data entry)	
Input Specifications	TB	100uVrms at max. gain for 0dB reading Input impedance : 3.2kOhm
	CD	7mVrms at max. gain for 0dB reading Input impedance : 47kOhm
	TF	100uVrms at max. gain for 0dB reading Input impedance : 3.2kOhm
	Wave files	Plays wave file from Internal SD card
	Pat. Resp.	Handheld push button
Output Specifications	FF1 & 2	7Vrms at min. 2kOhm load 60-20000Hz -3dB
	Left & Right	7Vrms at 10 Ohms load 60-20000Hz -3dB
	Bone	7Vrms at 10 Ohms load 60-8000Hz -3dB
	Monitor	2x 3Vrms at 32 Ohms / 1.5Vrms at 8 Ohms load 60-20000Hz -3dB



5.1 Calibration properties

Calibrated Transducers:	Contralateral Earphone:	Telephonics TDH39/DD45 with a static force of 4.5N 0.5N and/or EARTone 3A and/or CIR insert phone
	Probe system:	Ipsilateral Earphone: is integrated in the probe system
		Probe frequency transmitter and receiver and pressure transducer is integrated in the probe system
Accuracy:	General	Generally, the instrument is made and calibrated to be within and better than the tolerances required in the specified standards:
	Reflex Frequencies:	±1%
	Contralateral Reflex and Audiometer Tone Levels:	3 dB for 250 to 4000Hz and 5 dB for 6000 to 8000Hz
	Ipsilateral Reflex Tone Levels:	5 dB for 500 to 2000Hz and +5/-10 dB for 3000 to 4000Hz
	Pressure measurement : Compliance measurement:	5% or 10 daPa, whichever is greater 5% or 0.1 ml, whichever is greater
Stimulus Presentation Control:	Reflexes:	ON-OFF ratio ≥ 70 dB Rise time = 20 ms Fall time = 20 ms A weighted SPL in Off = 31 dB
Impedance calibration properties		
Probe tone	Frequencies:	226 Hz 1%, 678 Hz 1%, 800 Hz 1%, 1000 Hz 1%
	Level:	85 dB SPL 1.5 dB measured in an IEC 60318-5 acoustic coupler. The level is constant for all volumes in the measurement range.
	Distortion:	Max 1% THD
Compliance	Range:	0.1 to 8.0 ml
	Temperature dependence:	-0.003 ml/C
	Pressure dependence:	-0.00020 ml/daPa
	Reflex sensitivity: Reflex artifact level:	0.001 ml is the lowest detectable volume change ≥95 dB SPL (measured in the 711 coupler, 0.2 ml, 0.5 ml, 2.0 ml & 5.0 ml hard walled cavities).
	Temporal reflex characteristics: (IEC60645-5 clause 5.1.6)	Initial latency = 35 ms (5 ms) Rise time = 42 ms (5 ms) Terminal latency = 23 ms (5 ms) Fall time = 44 ms (5 ms) Overshoot = max. 1% Undershoot = max. 1%
Pressure	Range:	Values between -600 to +400 daPa can be selected in the setup.
	Safety limits:	-750 daPa and +550 daPa, 50 daPa
Barometric pressure	The barometer pressure changes influence on the impedance measurement in the specified range (97300 – 105300calibration Pascal).	Admittance can vary inside: ± 4% The pressure accuracy is: ±10 daPa or 10%, whichever is greater.



Height above sea level	The pressure sensor used, is a differential/gauge type, which means, it measures the pressure difference and therefore not affected of the height above sea level.					
	Probe tones	0 meters	500 meters	1000 meters	2000 meters	4000 meters
	226 Hz	1.0 mmho	1.06 mmho	1.13 mmho	1.28 mmho	1.65 mmho
	678 Hz	3.0 mmho	3.19 mmho	3.40 mmho	3.85 mmho	4.95 mmho
	800 Hz	3.54 mmho	3.77 mmho	4.01 mmho	4.55 mmho	5.84 mmho
	1000 Hz	4.42 mmho	4.71 mmho	5.01 mmho	5.68 mmho	7.30 mmho
	The pressure accuracy is: ± 10 daPa or 10%, whichever is greater.					
	To minimize the influence of temperature, barometer pressure, humidity, and height above sea level, it always recommended to calibrate the unit in the local positions.					
Temperature	The temperature has no theoretic impact on the impedance calculation, but the temperature has influence on the electronic circuits. This temperature influence for the standard specified temperature range (15-35 °C) is inside: Admittance can vary inside: $\pm 5\%$, $\pm 0.1 \text{ cm}^3$, $\pm 10^{-9} \text{ m}^3/\text{Pa}\cdot\text{s}$, whichever is greater.					
Reflex calibration standards and spectral properties:						
General	Specifications for stimulus and audiometer signals are made to follow IEC 60645-5					
Contralateral Earphone	Pure tone:	ISO 389-1 for TDH39 and ISO 389-2 for CIR.				
	Wide Band noise (WB): Spectral properties:	Interacoustics Standard As "Broad band noise" specified in IEC 60645-5, but with 500 Hz as lower cut-off frequency.				
	Low Pass noise (LP): Spectral properties:	Interacoustics Standard Uniform from 500 Hz to 1600 Hz, 5 dB re. 1000 Hz level				
	High Pass noise (HP): Spectral properties:	Interacoustics Standard Uniform from 1600 Hz to 10KHz, 5 dB re. 1000 Hz level				
Ipsilateral Earphone	Pure tone:	Interacoustics Standard.				
	Wide Band noise (WB): Spectral properties:	Interacoustics Standard As "Broad band noise" specified in IEC 60645-5, but with 500 Hz as lower cut-off frequency.				
	Low Pass noise (LP): Spectral properties:	Interacoustics Standard Uniform from 500 Hz to 1600 Hz, 10 dB re. 1000 Hz level				
	High Pass noise (HP): Spectral properties:	Interacoustics Standard Uniform from 1600 Hz to 4000 Hz, 10 dB re. 1000 Hz level				
	General about levels:	The actual sound pressure level at the eardrum will depend on the volume of the ear.				
The risk of artifacts at higher stimulus levels in reflex measurements are minor and will not activate the reflex detection system						



Reference values for stimulus calibration

RETSP	Freq.	Reference Equivalent Threshold Sound Level (RET SPL) [dB re. 20 µPa]						Variation of Ipsi stimulus levels for different volumes of the ear canal Relative to the calibration performed on an IEC 126 coupler [dB]		Sound attenuation values for TDH39/DD45 earphones using MX41/AR or PN51 cushion [dB]
	[Hz]	ISO 389-1 (Interacoustics Standard)	ISO 389-2 (Interacoustics Standard)	Interacoustics Standard	Interacoustics Standard	Interacoustics Standard	ISO 389-4 (ISO 8798)	0.5 ml	1 ml	
		TDH39	EARTone 3A / IP30	DD65 v2	DD45	Probe	NB Stimulus Correction Values			
	125	45	26	30,5	47.5	41	4			3
	250	25.5	14	17	27	24.5	4			5
	500	11.5	5.5	8	13	9.5	4	9.7	5.3	7
	1000	7	0	4,5	6	6.5	6	9.7	5.3	15
	1500	6.5	2	2,5	8	5	6			21 (1600 Hz)
	2000	9	3	2,5	8	12	6	11.7	3.9	26
	3000	10	3.5	2	8	11	6	-0.8	-0.5	31 (3150 Hz)
	4000	9.5	5.5	9,5	9	3.5	5	-1.6	-0.8	32
	6000	15.5	2	21	20.5	3	5			26 (6300 Hz)
	8000	13	0	21	12	-5	5			24
	WB	-8	-5	-8	-8	-5		7.5	3.2	
	LP	-6	-7	-6	-6	-7		8.0	3.6	
	HP	-10	-8	-10	-10	-8		3.9	1.4	

*All figures in bold are Interacoustics Standard values.



Coupler types used for calibration

IMP:

TDH39 and DD45 is calibrated using a 6cc acoustic coupler made in accordance with IEC 60318-3, Ipsilateral earphone and probe tone are calibrated using a 2cc acoustic coupler made in accordance with IEC 60318-5.

General information about specifications

Interacoustics continuously strives to improve its products and their performance. Therefore, the specifications can be subject to change without notice.

The performance and specifications of the instrument can only be guaranteed if it is subject to technical maintenance at least once per year. This should be carried out by a workshop authorized by Interacoustics.

Interacoustics puts diagrams and service manuals at the disposal of authorized service companies.

Enquiries about representatives and products may be sent to:

Interacoustics A/S	Phone:	+45 63713555
Audiometer Allé 1	Fax:	+45 63713522
5500 Middelfart	E-mail:	info@interacoustics.com
Denmark	http:	www.interacoustics.com



5.2 Reference equivalent threshold values for transducers

5.2.1 Impedance - Frequencies and intensity ranges

AA222 Maximums IMP										
	TDH39		DD65 v2		EARtone 3A / IP30		IPSI		DD45	
Center	Reading		Reading		Reading		Reading		Reading	
Freq.	Tone	NB	Tone	NB	Tone	NB	Tone	NB	Tone	NB
[Hz]	[dB HL]	[dB HL]	[dB HL]	[dB HL]	[dB HL]	[dB HL]	[dB HL]	[dB HL]	[dB HL]	[dB HL]
125	85	65	85	75	100	90	70	60	85	65
250	105	90	100	90	110	100	85	75	105	90
500	120	105	110	100	115	110	100	85	120	105
750	120	110	115	105	120	110	100	85	120	110
1000	120	110	115	105	120	110	105	90	120	110
1500	120	110	115	105	120	110	110	90	120	110
2000	120	110	115	105	120	110	105	90	120	110
3000	120	110	115	105	120	110	95	90	120	110
4000	120	110	110	100	120	105	100	85	120	110
6000	120	100	100	90	115	100	85	80	110	100
8000	110	100	95	85	90	95	80	75	110	100
10000										
WB	-	120	-	120	-	120	-	105	-	120
LP	-	120	-	120	-	120	-	110	-	120
HP	-	120	-	120	-	120	-	105	-	120



5.2.2 Audiometry – Survey of reference and max hearing level tone audiometry

Pure Tone RETSPL											
Transducer	DD45	TDH39	HDA280	DD450	HDA300	DD65 v2	EAR3A	IP30	EAR5A	B71	B81
Impedance	10 Ω	10 Ω	37 Ω	40 Ω	23 Ω	10 Ω	10 Ω	10 Ω	10 Ω	10 Ω	12.5 Ω
Coupler	6ccm	6ccm	6ccm	Artificial ear	Artificial ear	Artificial ear	2ccm	2ccm	2ccm	Mastoid	Mastoid
	RETSPL L	RETSPL L	RETSPL	RETSPL	RETSPL	RETSPL	RETSPL L	RETSPL	RETSPL	RETFL	RETFL
Tone 125 Hz	47.5	45	38.5	30.5	27	30,5	26	26	26		
Tone 160 Hz	40.5	37.5	33.5	26	24.5	25,5	22	22	22		
Tone 200 Hz	33.5	31.5	29.5	22	22.5	21,5	18	18	18		
Tone 250 Hz	27	25.5	25	18	20	17	14	14	14	67	67
Tone 315 Hz	22.5	20	21	15.5	16	14	12	12	12	64	64
Tone 400 Hz	17.5	15	17	13.5	12	10,5	9	9	9	61	61
Tone 500 Hz	13	11.5	13	11	8	8	5.5	5.5	5.5	58	58
Tone 630 Hz	9	8.5	10.5	8	6	6,5	4	4	4	52.5	52.5
Tone 750 Hz	6.5	8 / 7.5	9	6	4.5	5,5	2	2	2	48.5	48.5
Tone 800 Hz	6.5	7	8.5	6	4	5	1.5	1.5	1.5	47	47
Tone 1000 Hz	6	7	7.5	5.5	2	4,5	0	0	0	42.5	42.5
Tone 1250 Hz	7	6.5	8.5	6	2.5	3,5	2	2	2	39	39
Tone 1500 Hz	8	6.5	9.5	5.5	3	2,5	2	2	2	36.5	36.5
Tone 1600 Hz	8	7	9	5.5	2.5	2,5	2	2	2	35.5	35.5
Tone 2000 Hz	8	9	8	4.5	0	2,5	3	3	3	31	31
Tone 2500 Hz	8	9.5	7	3	-2	2	5	5	5	29.5	29.5
Tone 3000 Hz	8	10	6.5	2.5	-3	2	3.5	3.5	3.5	30	30
Tone 3150 Hz	8	10	7	4	-2.5	3	4	4	4	31	31
Tone 4000 Hz	9	9.5	9.5	9.5	-0.5	9,5	5.5	5.5	5.5	35.5	35.5
Tone 5000 Hz	13	13	12	14	10.5	15,5	5	5	5	40	40
Tone 6000 Hz	20.5	15.5	19	17	21	21	2	2	2	40	40
Tone 6300 Hz	19	15	19	17.5	21.5	21	2	2	2	40	40
Tone 8000 Hz	12	13	18	17.5	23	21	0	0	0	40	40

DD45 6ccm uses IEC60318-3 or NBS 9A coupler and RETSPL comes from PTB – DTU report 2009-2010. Force 4.5N ±0.5N.

TDH39 6ccm uses IEC60318-3 or NBS 9A coupler and RETSPL comes from ANSI S3.6 2010 and ISO 389-1 1998. Force 4.5N ±0.5N.

HDA280 6ccm uses IEC60318-3 or NBS 9A coupler and RETSPL comes from ANSI S3.6 2010 and PTB 2004. Force 5.0N ±0.5N.

HDA300 Artificial ear uses IEC60318-1 coupler with type 1 adaptor and RETSPL comes from PTB report 2012. Force 8.8N ±0.5N.

IP30 / EAR3A/EAR 5A 2ccm uses ANSI S3.7-1995 IEC60318-5 coupler (HA-2 with 5mm rigid Tube) and RETSPL comes from ANSI S3.6 2010 and ISO 389-2 1994.

DD65 v2 Artificial ear uses IEC60318-1 coupler with type 1 adaptor and RETSPL comes from ANSI S3.6 2018 and PTB 1.61-4091606 2018. Force 10N ±0.5N.

B71 / B81 uses ANSI S3.13 or IEC60318-6 2007 mechanical coupler and RETFL come from ANSI S3.6 2010 and ISO 389-3 1994. Force 5.4N ±0.5N.



Pure Tone max HL											
Transducer	DD45	TDH39	HDA280	DD450	HDA300	DD65 v2	EAR3A	IP30	EAR5A	B71	B81
Impedance	10 Ω	10 Ω	37 Ω	40 Ω	23 Ω	10 Ω	10 Ω	10 Ω	10 Ω	10 Ω	12.5 Ω
Coupler	6ccm	6ccm	6ccm	Artificial ear	Artificial ear	Artificial ear	2ccm	2ccm	2ccm	Mastoid	Mastoid
Signal	Max HL	Max HL	Max HL	Max HL	Max HL	Max HL	Max HL	Max HL	Max HL	Max HL	Max HL
Tone 125 Hz	90	90	105	100	115.0	85	90.0	90.0	95		
Tone 160 Hz	95	95	110	105	120	90	95	95	95		
Tone 200 Hz	100	100	115	105	120	95	100	100	100		
Tone 250 Hz	110	110	120	110	120	100	105	105	100	45	50
Tone 315 Hz	115	115	120	115	120	105	105	105	105	50	60
Tone 400 Hz	120	120	120	115	120	110	110	110	105	65	70
Tone 500 Hz	120	120	120	115	120	110	110	110	110	65	70
Tone 630 Hz	120	120	120	120	120	110	115	115	115	70	75
Tone 750 Hz	120	120	120	120	120	115	115	115	120	70	75
Tone 800 Hz	120	120	120	120	120	115	115	115	120	70	75
Tone 1000 Hz	120	120	120	120	120	115	120	120	120	70	85
Tone 1250 Hz	120	120	120	110	120	115	120	120	120	70	90
Tone 1500 Hz	120	120	120	115	120	115	120	120	120	70	90
Tone 1600 Hz	120	120	120	115	120	115	120	120	120	70	90
Tone 2000 Hz	120	120	120	115	120	115	120	120	120	75	90
Tone 2500 Hz	120	120	120	115	120	115	120	120	120	80	85
Tone 3000 Hz	120	120	120	115	120	115	120	120	120	80	85
Tone 3150 Hz	120	120	120	115	120	115	120	120	120	80	85
Tone 4000 Hz	120	120	120	115	120	110	115	115	120	80	85
Tone 5000 Hz	120	120	120	105	120	105	105	105	110	60	70
Tone 6000 Hz	115	120	115	105	110	100	100	100	105	50	60
Tone 6300 Hz	115	120	115	105	110	100	100	100	105	50	55
Tone 8000 Hz	110	110	105	105	110	95	95	95	100	50	50

NB noise effective masking level											
Transducer	DD45	TDH39	HDA280	DD450	HDA300	DD65 v2	EAR3A	IP30	EAR5A	B71	B81
Impedance	10 Ω	10 Ω	37 Ω	40 Ω	23 Ω	10 Ω	10 Ω	10 Ω	10 Ω	10 Ω	12.5 Ω
Coupler	6ccm	6ccm	6ccm	Artificial ear	Artificial ear	Artificial ear	2ccm	2ccm	2ccm	Mastoid	Mastoid
	EM	EM	EM	EM	EM	EM	EM	EM	EM	EM	EM
NB 125 Hz	51.5	49	42.5	34.5	31.0	34.5	30.0	30.0	30		
NB 160 Hz	44.5	41.5	37.5	30	28.5	29.5	26	26	26		
NB 200 Hz	37.5	35.5	33.5	26	26.5	25.5	22	22	22		
NB 250 Hz	31	29.5	29	22	24	21	18	18	18	71	71
NB 315 Hz	26.5	24	25	19.5	20	18	16	16	16	68	68
NB 400 Hz	21.5	19	21	17.5	16	14.5	13	13	13	65	65
NB 500 Hz	17	15.5	17	15	12	12	9.5	9.5	9.5	62	62
NB 630 Hz	14	13.5	15.5	13	11	11.5	9	9	9	57.5	57.5
NB 750 Hz	11.5	12.5	14	11	9.5	10.5	7	7	7	53.5	53.5
NB 800 Hz	11.5	12	13.5	11	9	10	6.5	6.5	6.5	52	52
NB 1000 Hz	12	13	13.5	11.5	8	10.5	6	6	6	48.5	48.5
NB 1250 Hz	13	12.5	14.5	12	8.5	9.5	8	8	8	45	45
NB 1500 Hz	14	12.5	15.5	11.5	9	8.5	8	8	8	42.5	42.5
NB 1600 Hz	14	13	15	11.5	8.5	8.5	8	8	8	41.5	41.5
NB 2000 Hz	14	15	14	10.5	6	8.5	9	9	9	37	37
NB 2500 Hz	14	15.5	13	9	4	8	11	11	11	35.5	35.5
NB 3000 Hz	14	16	12.5	8.5	3	8	9.5	9.5	9.5	36	36
NB 3150 Hz	14	16	13	10	3.5	9	10	10	10	37	37
NB 4000 Hz	14	14.5	14.5	14.5	4.5	1.5	10.5	10.5	10.5	40.5	40.5
NB 5000 Hz	18	18	17	19	15.5	20.5	10	10	10	45	45
NB 6000 Hz	25.5	20.5	24	22	26	26	7	7	7	45	45
NB 6300 Hz	24	20	24	22.5	26.5	26	7	7	7	45	45
NB 8000 Hz	17	18	23	22.5	28	26	5	5	5	45	45
White noise	0	0	0	0	0	0	0	0	0	42.5	42.5

Effective masking value is RETSPL / RETFL add 1/3 octave correction for Narrow-band noise from ANSI S3.6 2010 or ISO389-4 1994.



NB noise max HL											
Transducer	DD45	TDH39	HDA280	DD450	HDA300	DD65 v2	EAR3A	IP30	EAR5A	B71	B81
Impedance	10 Ω	10 Ω	37 Ω	40 Ω	23 Ω	10 Ω	10 Ω	10 Ω	10 Ω	10 Ω	12.5 Ω
Coupler	6ccm	6ccm	6ccm	Artificial ear	Artificial ear	Artificial ear	2ccm	2ccm	2ccm	Mastoid	Mastoid
	Max HL	Max HL	Max HL	Max HL	EM	Max HL	Max HL	Max HL	Max HL	Max HL	Max HL
NB 125 Hz	75	75	75	75	80.0	75	90.0	90.0	85		
NB 160 Hz	80	85	80	80	85	80	95	95	90		
NB 200 Hz	90	90	85	80	85	85	100	100	95		
NB 250 Hz	95	95	90	85	90	90	105	105	100	35	40
NB 315 Hz	100	100	95	90	90	95	105	105	100	40	50
NB 400 Hz	105	105	95	95	95	100	105	105	105	55	60
NB 500 Hz	110	110	100	95	100	100	110	110	110	55	60
NB 630 Hz	110	110	100	95	100	100	110	110	110	60	65
NB 750 Hz	110	110	105	100	100	105	110	110	110	60	65
NB 800 Hz	110	110	105	100	105	105	110	110	110	60	65
NB 1000 Hz	110	110	105	100	105	105	110	110	110	60	70
NB 1250 Hz	110	110	105	95	105	105	110	110	110	60	75
NB 1500 Hz	110	110	105	100	105	105	110	110	110	60	75
NB 1600 Hz	110	110	105	100	105	105	110	110	110	60	75
NB 2000 Hz	110	110	105	100	105	105	110	110	110	65	70
NB 2500 Hz	110	110	105	100	110	105	110	110	110	65	65
NB 3000 Hz	110	110	105	100	110	105	110	110	110	65	65
NB 3150 Hz	110	110	105	100	110	100	110	110	110	65	65
NB 4000 Hz	110	110	105	100	110	100	110	110	110	65	60
NB 5000 Hz	110	110	105	95	100	95	105	105	110	50	55
NB 6000 Hz	105	110	95	90	95	90	100	100	105	45	50
NB 6300 Hz	105	110	95	90	95	90	100	100	105	40	45
NB 8000 Hz	100	100	90	90	95	90	95	95	100	40	40
White noise	120	120	120	115	115	85	110	110	110	70	70

ANSI Speech RETSPL											
Transducer	DD45	TDH39	HDA280	DD450	HDA300	DD65 v2	EAR3A	IP30	EAR5A	B71	B81
Impedance	10 Ω	10 Ω	37 Ω	40 Ω	23 Ω	10 Ω	10 Ω	10 Ω	10 Ω	10 Ω	12.5 Ω
Coupler	6ccm	6ccm	6ccm	Artificial ear	Artificial ear	Artificial ear	2ccm	2ccm	2ccm	Mastoid	Mastoid
	RETSPL	RETSPL	RETSPL	RETSPL	RETSPL	RETSPL	RETSPL	RETSPL	RETSPL	RETSPL	RETSPL
Speech	18.5	19.5	20	19	14.5	17					
Speech Equ.FF.	18.5	15.5	21.5	18.5	16	16.5					
Speech Non-linear	6	7	7.5	5.5	2	4.5	12.5	12.5	12.5	55	55
Speech noise	18.5	19.5	20	19	14.5	17					
Speech noise Equ.FF.	18.5	15.5	21.5	18.5	16	16.5					
Speech noise Non-linear	6	7	7.5	5.5	2	4.5	12.5	12.5	12.5	55	55
White noise in speech	21	22	22.5	21.5	17	19.5	15	15	15	57.5	57.5

DD45 (G_F-G_C) PTB-DTU report 2009-2010.

TDH39 (G_F-G_C) ANSI S3.6 2010.

HDA280 (G_F-G_C) PTB report 2004.

HDA300 (G_F-G_C) PTB report 2013.

ANSI Speech level 12.5 dB + 1 kHz RETSPL ANSI S3.6 2010 (acoustical linear weighting)

ANSI Speech Equivalent free field level 12.5 dB + 1 kHz RETSPL – (G_F-G_C) from ANSI S3.6 2010(acoustical equivalent sensitivity weighting)

ANSI Speech Not linear level 1 kHz RETSPL ANSI S3.6 2010 (DD45-TDH39-HDA300) and EAR3A –IP30-CIR- B71-B81 12.5 dB + 1 kHz RETSPL ANSI S3.6 2010 (no weighting)



IEC Speech RETSPL											
Transducer	DD45	TDH39	HDA280	DD450	HDA300	DD65 v2	EAR3A	IP30	EAR5A	B71	B81
Impedance	10 Ω	10 Ω	37 Ω	40 Ω	23 Ω	10 Ω	10 Ω	10 Ω	10 Ω	10 Ω	12.5 Ω
Coupler	6ccm	6ccm	6ccm	Artificial ear	Artificial ear	Artificial ear	2ccm	2ccm	2ccm	Mastoid	Mastoid
	RETSPL	RETSPL	RETSPL	RETSPL	RETSPL	RETSPL	RETSPL	RETSPL	RETSPL	RETFL	RETFL
Speech	20	20	20	20	20	20					
Speech Equ.FF.	3.5	0.5	6.5	3.5	1	1,5					
Speech Non-linear	6	7	7.5	5.5	2	4,5	20	20	20	55	55
Speech noise	20	20	20	20	20	20					
Speech noise Equ.FF.	3.5	0.5	6.5	3.5	1	1,5					
Speech noise Non-linear	6	7	7.5	5.5	2	4,5	20	20	20	55	55
White noise in speech	22.5	22.5	22.5	22.5	22.5	22,5	22.5	22.5	22.5	57.5	57.5

DD45 (G_F-G_C) PTB-DTU report 2009-2010.

TDH39 (G_F-G_C) IEC60645-2 1997.

HDA280 (G_F-G_C) PTB report 2004.

HDA300 (G_F-G_C) PTB report 2013.

IEC Speech level IEC60645-2 1997 (acoustical linear weighting)

IEC Speech Equivalent free field level (G_F-G_C) from IEC60645-2 1997 (acoustical equivalent sensitivity weighting)

IEC Speech Not linear level 1 kHz RETSPL (DD45-TDH50-HDA300) and EAR3A – IP30 - B71- B81 IEC60645-2 1997 (no weighting)



IEC Speech max HL											
Transducer	DD45	TDH39	HDA280	DD450	HDA300	DD65 v2	EAR3A	IP30	EAR5A	B71	B81
Impedance	10 Ω	10 Ω	37 Ω	40 Ω	23 Ω	10 Ω	10 Ω	10 Ω	10 Ω	10 Ω	12.5 Ω
Coupler	6ccm	6ccm	6ccm	Artificial ear	Artificial ear	Artificial ear	2ccm	2ccm	2ccm	Mastoid	Mastoid
	Max HL	Max HL	Max HL	Max HL	Max HL	Max HL	Max HL	Max HL	Max HL	Max HL	Max HL
Speech	110	110	100	90	95	95					
Speech Equ.FF.	115	120	110	100	110	110					
Speech Non-linear	120	120	120	110	120	110	100	100	100	60	60
Speech noise	100	100	95	85	90	90					
Speech noise Equ.FF.	115	115	105	95	110	100					
Speech noise Non-linear	115	115	120	105	120	105	90	90	90	50	50
White noise in speech	95	95	95	90	95	95	85	85	85	55	60

Sweden Speech RETSPL											
Transducer	DD45	TDH39	HDA280	DD450	HDA300	DD6 v2	EAR3A	IP30	EAR5A	B71	B81
Impedance	10 Ω	10 Ω	37 Ω	40 Ω	23 Ω	10 Ω	10 Ω	10 Ω	10 Ω	10 Ω	12.5 Ω
Coupler	6ccm	6ccm	6ccm	Artificial ear	Artificial ear	Artificial ear	2ccm	2ccm	2ccm	Mastoid	Mastoid
	RETSPL	RETSPL	RETSPL	RETSPL	RETSPL	RETSPL	RETSPL	RETSPL	RETSPL	RETSPL	RETSPL
Speech	22	22	20	20	20	20					
Speech Equ.FF.	3.5	0.5	6.5	3.5	1	1,5					
Speech Non-linear	22	22	7.5	5.5	2	4,5	21	21	21	55	55
Speech noise	27	27	20	20	20	20					
Speech noise Equ.FF.	3.5	0.5	6.5	3.5	1	1,5					
Speech noise Non-linear	27	27	7.5	5.5	2	4,5	26	26	26	55	55
White noise in speech	22.5	22.5	22.5	22.5	22.5	22,5	22.5	22.5	22.5	57.5	57.5

DD45 (G_F-G_C) PTB-DTU report 2009-2010.

TDH39 (G_F-G_C) IEC60645-2 1997.

HDA280 (G_F-G_C) PTB report 2004.

HDA300 (G_F-G_C) PTB report 2013.

Sweden Speech level STAF 1996 and IEC60645-2 1997 (acoustical linear weighting)

Sweden Speech Equivalent free field level (G_F-G_C) from IEC60645-2 1997 (acoustical equivalent sensitivity weighting)

Sweden Speech Not linear level 1 kHz RETSPL (DD45-TDH39-HDA300) and EAR3A – IP30 – CIR - B71-B81 STAF 1996 and IEC60645-2 1997 (no weighting)

Sweden Speech max HL											
Transducer	DD45	TDH39	HDA280	DD450	HDA300	DD65 v2	EAR3A	IP30	EAR5A	B71	B81
Impedance	10 Ω	10 Ω	37 Ω	40 Ω	23 Ω	10 Ω	10 Ω	10 Ω	10 Ω	10 Ω	12.5 Ω
Coupler	6ccm	6ccm	6ccm	Artificial ear	Artificial ear	Artificial ear	2ccm	2ccm	2ccm	Mastoid	Mastoid
	Max HL	Max HL	Max HL	Max HL	Max HL	Max HL	Max HL	Max HL	Max HL	Max HL	Max HL
Speech	108	108	100	90	95	95					
Speech Equ.FF.	115	120	110	100	110	110					
Speech Non-linear	104	105	120	110	120	110	99	99	99	60	60
Speech noise	93	93	95	85	90	90					
Speech noise Equ.FF.	115	115	105	95	110	100					
Speech noise Non-linear	94	95	120	105	120	105	84	84	84	50	50
White noise in speech	95	95	95	90	95	95	85	85	85	55	60



Norway Speech RETSPL											
Transducer	DD45	TDH39	HDA280	DD450	HDA300	DD65 v2	EAR3A	IP30	EAR5A	B71	B81
Impedance	10 Ω	10 Ω	37 Ω	40 Ω	23 Ω	10 Ω	10 Ω	10 Ω	10 Ω	10 Ω	12.5 Ω
Coupler	6ccm	6ccm	6ccm	Artificial ear	Artificial ear	Artificial ear	2ccm	2ccm	2ccm	Mastoid	Mastoid
	RETSPL	RETSPL	RETSPL	RETSPL	RETSPL	RETSPL	RETSPL	RETSPL	RETSPL	RETFL	RETFL
Speech	40	40	40	40	40	20					
Speech Equ.FF.	3.5	0.5	6.5	3.5	1	1.5					
Speech Non-linear	6	7	7.5	5.5	2	4.5	40	40	40	75	75
Speech noise	40	40	40	40	40	20					
Speech noise Equ.FF.	3.5	0.5	6.5	3.5	1	1.5					
Speech noise Non-linear	6	7	7.5	5.5	2	4.5	40	40	40	75	75
White noise in speech	22.5	22.5	22.5	22.5	22.5	22.5	22.5	22.5	22.5	57.5	57.5

DD45 (G_F-G_C) PTB-DTU report 2009-2010.

TDH39 (G_F-G_C) IEC60645-2 1997.

HDA280 (G_F-G_C) PTB report 2004.

HDA300 (G_F-G_C) PTB report 2013.

Norway Speech level IEC60645-2 1997+20dB (acoustical linear weighting)

Norway Speech Equivalent free field level (G_F-G_C) from IEC60645-2 1997 (acoustical equivalent sensitivity weighting)

Norway Speech Not linear level 1 kHz RETSPL (DD45-TDH39-HDA300) and EAR3A – IP30 – CIR - B71-B81 IEC60645-2 1997 +20dB (no weighting)

Norway Speech max HL											
Transducer	DD45	TDH39	HDA280	DD450	HDA300	DD65 v2	EAR3A	IP30	EAR5A	B71	B81
Impedance	10 Ω	10 Ω	37 Ω	40 Ω	23 Ω	10 Ω	10 Ω	10 Ω	10 Ω	10 Ω	12.5 Ω
Coupler	6ccm	6ccm	6ccm	Artificial ear	Artificial ear	Artificial ear	2ccm	2ccm	2ccm	Mastoid	Mastoid
	Max HL	Max HL	Max HL	Max HL	Max HL	Max HL	Max HL	Max HL	Max HL	Max HL	Max HL
Speech	90	90	80	70	75	95					
Speech Equ.FF.	115	120	110	100	110	110					
Speech Non-linear	120	120	120	110	120	110	80	80	80	40	40
Speech noise	80	80	75	65	70	90					
Speech noise Equ.FF.	115	115	105	95	110	100					
Speech noise Non-linear	115	115	120	105	120	105	70	70	70	30	30
White noise in speech	95	95	95	90	95	95	85	85	85	55	60



Free Field						
ANSI S3.6-2010				Free Field max SPL		
ISO 389-7 2005				Free Field max HL is found by subtracting the selected RETSPL value		
Frequency Hz	Binaural			Binaural to Monaural	Free Field Line	
	0°	45°	90°	correction	Tone Max SPL	NB Max SPL
	RETSPL dB	RETSPL dB	RETSPL dB	RETSPL dB	dB	dB
125	22	21.5	21	2	102	97
160	18	17	16.5	2	98	93
200	14.5	13.5	13	2	104.5	99.5
250	11.5	10.5	9.5	2	106.5	101.5
315	8.5	7	6	2	103.5	98.5
400	6	3.5	2.5	2	106	101
500	4.5	1.5	0	2	104.5	99.5
630	3	-0.5	-2	2	103	98
750	2.5	-1	-2.5	2	102.5	97.5
800	2	-1.5	-3	2	107	102
1000	2.5	-1.5	-3	2	102.5	97.5
1250	3.5	-0.5	-2.5	2	103.5	98.5
1500	2.5	-1	-2.5	2	102.5	97.5
1600	1.5	-2	-3	2	106.5	101.5
2000	-1.5	-4.5	-3.5	2	103.5	98.5
2500	-4	-7.5	-6	2	101	96
3000	-6	-11	-8.5	2	104	94
3150	-6	-11	-8	2	104	94
4000	-5.5	-9.5	-5	2	104.5	99.5
5000	-1.5	-7.5	-5.5	2	108.5	98.5
6000	4.5	-3	-5	2	104.5	99.5
6300	6	-1.5	-4	2	106	96
8000	12.5	7	4	2	92.5	87.5
White Noise	0	-4	-5.5	2		100

ANSI Free Field							
ANSI S3.6-2010						Free Field max SPL	
						Free Field max HL is found by subtracting the selected RETSPL value	
	Binaural					Binaural to Monaural	Free Field Line
	0°	45°	90°	135°	180°	correction	0° - 45° - 90°
	RETSP L	RETSP L	RETSP L	RETSP L	RETSP L	RETSPL	Max SPL
Speech	15	11	9.5	10	13	2	100
Speech Noise	15	11	9.5	10	13	2	100
Speech WN	17.5	13.5	12	12.5	15.5	2	97.5



Equivalent Free Field					
Speech Audiometer					
	TDH39	DD45	HDA280	DD450	HDA300
	IEC60645-2 1997 ANSI S3.6-2010	PTB – DTU 2010	PTB	ISO389-8 2004	PTB 2013
Coupler	IEC60318-3	IEC60318-3	IEC60318-3	IEC60318-1	IEC60318-1
Frequency	G _F -G _c	G _F -G _c	G _F -G _c	G _F -G _c	G _F -G _c
125	-17,5	-21,5	-15,0	-5,0	-12,0
160	-14,5	-17,5	-14,0	-4,5	-11,5
200	-12,0	-14,5	-12,5	-4,5	-11,5
250	-9,5	-12,0	-11,5	-4,5	-11,5
315	-6,5	-9,5	-10,0	-5,0	-11,0
400	-3,5	-7,0	-9,0	-5,5	-10,0
500	-5,0	-7,0	-8,0	-2,5	-7,5
630	0,0	-6,5	-8,5	-2,5	-5,0
750			-5,0		
800	-0,5	-4,0	-4,5	-3,0	-3,0
1000	-0,5	-3,5	-6,5	-3,5	-1,0
1250	-1,0	-3,5	-11,5	-2,0	0,0
1500			-12,5		
1600	-4,0	-7,0	-12,5	-5,5	-0,5
2000	-6,0	-7,0	-9,5	-5,0	-2,0
2500	-7,0	-9,5	-7,0	-6,0	-3,0
3000			-10,5		
3150	-10,5	-12,0	-10,0	-7,0	-6,0
4000	-10,5	-8,0	-14,5	-13,0	-4,5
5000	-11,0	-8,5	-12,5	-14,5	-10,5
6000			-14,5		
6300	-10,5	-9,0	-15,5	-11,0	-7,0
8000	+1,5	-1,5	-9,0	-8,5	-10,0



Sound attenuation values for earphones				
Frequency	Attenuation			
	TDH39/DD45 with MX41/AR or PN 51 Cushion	EAR 3A IP30 EAR 5A	DD450	HDA300
[Hz]	[dB]*	[dB]*	[dB]*	[dB]
125	3	33	15	12.5
160	4	34	15	
200	5	35	16	
250	5	36	16	12.7
315	5	37	18	
400	6	37	20	
500	7	38	23	9.4
630	9	37	25	
750	-			
800	11	37	27	
1000	15	37	29	12.8
1250	18	35	30	
1500	-			
1600	21	34	31	
2000	26	33	32	15.1
2500	28	35	37	
3000	-			
3150	31	37	41	
4000	32	40	46	28.8
5000	29	41	45	
6000	-			
6300	26	42	45	
8000	24	43	44	26.2

*ISO 8253-1 2010



5.3 Pin assignments

Socket	Connector	Pin 1	Pin 2	Pin 3
IN 24V DC / 2.5A		Ground	24V in	-
Left & Right	 6.3mm Mono	Ground	Signal	-
Bone				
Contra				
Pat. Resp.				
TB	 6.3mm Stereo	Ground	DC bias	Signal
Assist Mon.	 3.5mm Stereo	Ground	Right	Left
TF		Ground	DC bias	Signal
CD		Ground	CD2	CD1
FF1 & FF2		Ground	Signal	-

USB A		USB B (Device)	
 4 3 2 1	1. +5 VDC	 1 2 4 3	1. +5 VDC
	2. Data -		2. Data -
	3. Data +		3. Data +
	4. Ground		4. Ground

LAN		
 RJ45 Socket	 RJ45 Cable Plug	1. TX+ Transmit Data+
		1. TX- Transmit Data-
		2. RX+ Receive Data+
		3. Not connected
		4. Not connected
		5. RX- Receive Data-
		6. Not connected
7. Not connected		



HDMI	
	1. TMDS Data2+
	2. TMDS Data2 Shield
	3. TMDS Data2-
	4. TMDS Data1+
	5. TMDS Data1 Shield
	6. TMDS Data1-
	7. TMDS Data0+
	8. TMDS Data0 Shield
	9. TMDS Data0-
	10. TMDS Data Clock+
	11. TMDS Data ClockShield
	12. TMDS Data Clock-
	13. CEC
	14. Reversed
	15. SCL
	16. SDA
	17. DDC/CEC/HEC Ground
	18. +5V
	19. Hot Plug Detect

Probe system	
	1. DSP I2C Interrupt
	2. GND
	3. IPSI out
	4. GND contra
	5. GND probe mic.
	6. DSP I2C SCLK
	7. GND
	8. GND ipsi
	9. Probe tone out
	10. Mic – in
	11. DSP I2C data
	12. +5V probe
	13. Contra out
	14. GND probe tone
	15. Mic + in



5.4 Electromagnetic compatibility (EMC)



CAUTION

- This instrument is suitable in hospital environments except for near active HF surgical equipment and RF shielded rooms of systems for magnetic resonance imaging, where the intensity of electromagnetic disturbance is high
- Use of this instrument adjacent to or stacked with other equipment should be avoided because it could result in improper operation. If such use is necessary, this instrument and the other equipment should be observed to verify that they are operating normally
- Use of accessories, transducers, and cables other than those specified or provided by the manufacturer of this equipment could result in increased electromagnetic emissions or decreased electromagnetic immunity of this equipment and result in improper operation. The list of accessories, transducers and cables can be found in this appendix.
- Portable RF communications equipment (including peripherals such as antenna cables and external antennas) should be used no closer than 30 cm (12 inches) to any part of this instrument, including cables specified by the manufacturer. Otherwise, degradation of the performance of this equipment could result

NOTICE

- **ESSENTIAL PERFORMANCE** for this instrument is defined by the manufacturer as:
This instrument does not have an **ESSENTIAL PERFORMANCE** Absence or loss of **ESSENTIAL PERFORMANCE** cannot lead to any unacceptable immediate risk
- Final diagnosis shall always be based on clinical knowledge There are no deviations from the collateral standard and allowances uses
- This instrument is following IEC60601-1-2:2014, emission class B group 1
NOTICE: There are no deviations from the collateral standard and allowances uses
NOTICE: All necessary instruction for maintaining compliance with regard to EMC can be found in the general maintenance section in this instruction. No further steps required.

Portable and mobile RF communications equipment can affect the AA222. Install and operate the AA222 according to the EMC information presented in this chapter. The AA222 has been tested for EMC emissions and immunity as a standalone AA222. Do not use the AA222 adjacent to or stacked with other electronic equipment. If adjacent or stacked use is necessary, the user should verify normal operation in the configuration.

The use of accessories, transducers, and cables other than those specified, with the exception of servicing parts sold by Interacoustics as replacement parts for internal components, may result in increased **EMISSIONS** or decreased **IMMUNITY** of the device.

Anyone connecting additional equipment is responsible for making sure the system complies with the IEC 60601-1-2 standard.



Guidance and manufacturer's declaration - electromagnetic emissions			
The AA222 is intended for use in the electromagnetic environment specified below. The customer or the user of the AA222 should assure that it is used in such an environment.			
Emissions Test	Compliance	Electromagnetic environment - guidance	
RF emissions CISPR 11	Group 1	The AA222 uses RF energy only for its internal function. Therefore, its RF emissions are very low and are not likely to cause any interference in nearby electronic equipment.	
RF emissions CISPR 11	Class B	The AA222 is suitable for use in all commercial, industrial, business, and residential environments.	
Harmonic emissions IEC 61000-3-2	Complies Class A Category		
Voltage fluctuations / flicker emissions IEC 61000-3-3	Complies		
Recommended separation distances between portable and mobile RF communications equipment and the AA222.			
The AA222 is intended for use in an electromagnetic environment in which radiated RF disturbances are controlled. The customer or the user of the AA222 can help prevent electromagnetic interferences by maintaining a minimum distance between portable and mobile RF communications equipment (transmitters) and the AA222 as recommended below, according to the maximum output power of the communications equipment.			
Rated Maximum output power of transmitter [W]	Separation distance according to frequency of transmitter [m]		
	150 kHz to 80 MHz $d = 1.17\sqrt{P}$	80 MHz to 800 MHz $d = 1.17\sqrt{P}$	800 MHz to 2.5 GHz $d = 2.23\sqrt{P}$
0.01	0.12	0.12	0.23
0.1	0.37	0.37	0.74
1	1.17	1.17	2.33
10	3.70	3.70	7.37
100	11.70	11.70	23.30
For transmitters rated at a maximum output power not listed above, the recommended separation distance d in meters (m) can be estimated using the equation applicable to the frequency of the transmitter, where P is the maximum output power rating of the transmitter in watts (W) according to the transmitter manufacturer. Note 1 At 80 MHz and 800 MHz, the higher frequency range applies. Note 2 These guidelines may not apply to all situations. Electromagnetic propagation is affected by absorption and reflection from structures, objects, and people.			



Guidance and manufacturer's declaration - Electromagnetic immunity			
The AA222 is intended for use in the electromagnetic environment specified below. The customer or the user of the AA222 should assure that it is used in such an environment.			
Immunity Test	IEC 60601 Test Level	Compliance	Electromagnetic Environment-Guidance
Electrostatic Discharge (ESD) IEC 61000-4-2	+6 kV contact +8 kV air	+6 kV contact +8 kV air	Floors should be wood, concrete, or ceramic tile. If floors are covered with synthetic material, the relative humidity should be greater than 30%.
Electrical fast transient/burst IEC61000-4-4	+2 kV for power supply lines +1 kV for input/output lines	+2 kV for power supply lines +1 kV for input/output lines	Mains power quality should be that of a typical commercial or residential environment.
Surge IEC 61000-4-5	+1 kV differential mode +2 kV common mode	+1 kV differential mode +2 kV common mode	Mains power quality should be that of a typical commercial or residential environment.
Voltage dips, short interruptions, and voltage variations on power supply lines IEC 61000-4-11	< 5% <i>UT</i> (>95% dip in <i>UT</i>) for 0.5 cycle 40% <i>UT</i> (60% dip in <i>UT</i>) for 5 cycles 70% <i>UT</i> (30% dip in <i>UT</i>) for 25 cycles <5% <i>UT</i> (>95% dip in <i>UT</i>) for 5 sec	< 5% <i>UT</i> (>95% dip in <i>UT</i>) for 0.5 cycle 40% <i>UT</i> (60% dip in <i>UT</i>) for 5 cycles 70% <i>UT</i> (30% dip in <i>UT</i>) for 25 cycles <5% <i>UT</i>	Mains power quality should be that of a typical commercial or residential environment. If the user of the AA222 requires continued operation during power mains interruptions, it is recommended that the AA222 be powered from an uninterruptable power supply or its battery.
Power frequency (50/60 Hz) IEC 61000-4-8	3 A/m	3 A/m	Power frequency magnetic fields should be at levels characteristic of a typical location in a typical commercial or residential environment.
Note: <i>UT</i> is the A.C. mains voltage prior to application of the test level.			



Guidance and manufacturer's declaration — electromagnetic immunity			
The AA222 is intended for use in the electromagnetic environment specified below. The customer or the user of the AA222 should assure that it is used in such an environment,			
Immunity test	IEC / EN 60601 test level	Compliance level	Electromagnetic environment – guidance
Conducted RF IEC / EN 61000-4-6	3 Vrms 150kHz to 80 MHz	3 Vrms	Portable and mobile RF communications equipment should be used no closer to any parts of the AA222, including cables, than the recommended separation distance calculated from the equation applicable to the frequency of the transmitter. Recommended separation distance $d = 1,2\sqrt{P}$ $d = 1,2\sqrt{P}$ 80 MHz to 800 MHz $d = 2,3\sqrt{P}$ 800 MHz to 2,5 GHz Where P is the maximum output power rating of the transmitter in watts (W) according to the transmitter manufacturer and d is the recommended separation distance in meters (m). Field strengths from fixed RF transmitters, as determined by an electromagnetic site survey, (a) should be less than the compliance level in each frequency range (b) Interference may occur in the vicinity of equipment marked with the following symbol: 
Radiated RF IEC / EN 61000-4-3	3 V/m 80 MHz to 2,5 GHz	3 V/m	
NOTE1 At 80 MHz and 800 MHz, the higher frequency range applies NOTE 2 These guidelines may not apply in all situations. Electromagnetic propagation is affected by absorption and reflection from structures, objects, and people.			
(a) Field strengths from fixed transmitters, such as base stations for radio (cellular/cordless) telephones and land mobile radios, amateur radio, AM and FM radio broadcast and TV broadcast cannot be predicted theoretically with accuracy. To assess the electromagnetic environment due to fixed RF transmitters, an electromagnetic site survey should be considered. If the measured field strength in the location in which the AA222 is used exceeds the applicable RF compliance level above, the AA222 should be observed to verify normal operation, If abnormal performance is observed, additional measures may be necessary, such as re-orienting or relocating the AA222. (b) Over the frequency range 150 kHz to 80 MHz, field strengths should be less than 3 V/m.			



To ensure compliance with the EMC requirements as specified in IEC 60601-1-2, it is essential to use only the following accessories:

ITEM	MANUFACTURER	MODEL
Power supply unit UE60	Interacoustics	UES65-240250SPA3
Clinical Probe	Interacoustics	Clinical probe system 1077/1078
Diagnostic probe	Interacoustics	Diagnostic probe system 1077/1078
DD45C Contra Headset DD45C contra headset P3045	Interacoustics	DD45C
IP30 Insert Phone 10ohm single contra	Interacoustics	IP30C
DD45 Audiometric Headset P3045	Interacoustics	DD45
IP30 Insert Phone 10ohm set	Interacoustics	IP30
B71/B81 Bone conductor headset 10 Ohm(lead-free)	Interacoustics	B71 /B81

Conformance to the EMC requirements as specified in IEC 60601-1-2 is ensured if the cable types and cable lengths are as specified below:

Description	Length	Screened/Unscreened
Mains Cable	2.0m	Unscreened
USB Cable	2.0m	Screened
Clinical Probe	2.0m	Unscreened
Diagnostic Probe	2.0m	Unscreened
DD45C contra headset P3045	2.0m	Screened
IP30 Insert Phone 10ohm single contra	2.0m	Screened
DD45 Audiometric Headset P3045	2.0m	Screened
IP30 Insert Phone 10ohm set	2.0m	Screened

Return Report – Form 001



Opr. dato: 2014-03-07 af: EC Rev. dato: 2015-04-15 af: MSt Rev. nr.: 4

Company: _____

Address: _____

Phone: _____

Fax or e-mail: _____

Address

DGS Diagnostics Sp. z o.o.
ul. Słoneczny Sad 4d
72-002 Doluje
Polska

Contact person: _____ Date: _____

Following item is reported to be:

- returned to INTERACOUSTICS for: repair, exchange, other: _____
- defective as described below with request of assistance
- repaired locally as described below
- showing general problems as described below

Item: _____ Type: _____ Quantity: _____
Serial No.: _____ Supplied by: _____
Included parts: _____

Important! - Accessories used together with the item must be included if returned (e.g. external power supply, headsets, transducers and couplers).

Description of problem or the performed local repair:

Returned according to agreement with: Interacoustics, Other : _____

Date : _____ Person : _____

Please provide e-mail address or fax No. to whom Interacoustics may confirm reception of the returned goods:

The above mentioned item is reported to be dangerous to patient or user ¹

In order to ensure instant and effective treatment of returned goods, it is important that this form is filled in and placed together with the item.

Please note that the goods must be carefully packed, preferably in original packing, in order to avoid damage during transport. (Packing material may be ordered from Interacoustics)

¹ EC Medical Device Directive rules require immediate report to be sent, if the device by malfunction deterioration of performance or characteristics and/or by inadequacy in labelling or instructions for use, has caused or could have caused death or serious deterioration of health to patient or user. Page 1 of 1