



Science **made** smarter

Instructions for Use - US

AS608



D-0127810-B – 2021/05



Interacoustics

Table of Contents

- 1 Introduction 1**
 - 1.1 About this Manual 1
 - 1.2 Intended Use 1
 - 1.3 Product Description 2
 - 1.4 Warnings..... 3
- 2 Unpacking and Installation 5**
 - 2.1 Unpacking and Inspection 5
 - 2.2 Marking 6
 - 2.3 Important safety instructions..... 7
 - 2.3.1 Electrical system safety 7
 - 2.3.2 Electrical safety..... 7
 - 2.3.3 Explosion hazards 8
 - 2.3.4 Electromagnetic compatibility (EMC)..... 8
 - 2.3.5 Cautions – General..... 8
 - 2.3.6 Environmental factors 9
 - 2.3.7 Disposal 9
 - 2.4 Malfunction 10
- 3 Getting Started - Setup and Installation..... 11**
 - 3.1 AS608 - Connection Panel Dictionary 11
 - 3.2 AS608 - Operation Panel Dictionary 12
 - 3.3 Air Conduction 13
 - 3.4 Power Up and Power Off..... 14
 - 3.5 Pure Tone Presentation..... 14
 - 3.6 AS608e Special Functions: 15
 - 3.7 Display: 15
 - 3.8 Setup Menu of AS608/AS608e..... 16
 - 3.9 About Diagnostic Suite 20
- 4 Care and Maintenance 21**
 - 4.1 General Maintenance Procedures..... 21
 - 4.2 How to clean Interacoustics Products 22
 - 4.1 Concerning Repair..... 22
 - 4.3 Warranty 22
- 5 General Technical Specifications..... 25**
 - 5.1 Reference Equivalent Threshold Values for transducers..... 27
 - 5.2 Maximum hearing level settings provided at each test frequency..... 27
 - 5.3 Pin Assignments 28
 - 5.4 Electromagnetic Compatibility (EMC)..... 28



1 Introduction

1.1 About this Manual

This manual is valid for the AS608. This product is manufactured by:

Interacoustics A/S

Audiometer Allé 1

5500 Middelfart

Denmark

Tel.: +45 6371 3555

Fax: +45 6371 3522

E-mail: info@interacoustics.com

Web: www.interacoustics.com

1.2 Intended Use

The AS608 screening audiometer is designed to be a device for screening for hearing loss. Output and specificity of this type of device are based on the test characteristics defined by the user and may vary depending on environmental and operating conditions. The screening for hearing loss using this kind of audiometer depends on the interaction with the patient. “normal hearing” result should not allow for ignoring other contra indications. A full audiologic evaluation should be administered if concerns about hearing sensitivity persist

The AS608 audiometer is intended to be used by an audiologist, hearing healthcare professionals, or trained technicians in a quiet environment. It is recommended that the instrument be operated within an ambient temperature range of 15-35 degree Celsius (59-95 degrees Fahrenheit)



1.3 Product Description

The AS608e extends the AS608 functionalities with the following three extra features:

- PC Integration through the Diagnostic Suite software. This enables audiograms to be transferred and displayed in the Windows software and stored in the OtoAccess® or Noah databases. The Diagnostic Suite also includes advanced reporting and printing features (similar to the AC440 software module.) Please refer to the Diagnostic Suite user manual for instructions about how to use the PC software suite.
- In addition to traditional manual testing, the AS608e incorporates a Hughson Westlake patient controlled automatic threshold test complying with ISO 8253. When the test is completed the results are easily recalled from the internal memory of the AS608.
- Talk Forward function that makes the AS608e easy to work with particularly in sound booth installations.

As standard AS608 is delivered with the following:

Included parts	DD45 Audiometric headset P3045 ¹ Battery Alkaline 1,5V 3x Instruction for use - Manual <u>AS608e</u> CD Diagnostic Suite + OtoAccess® + USB cable APS3 Patient Signal Button
Optional parts	DD65v2 Audiometric Headset ¹ DD45 Audiometric Headset P3100 ¹ DD45AA Audiometric Headset ¹ TDH39 Audiometric Headset HBA ¹ TDH39 Audiometric Headset P3045 ¹ TDH39 Audiometric Headset P3100 ¹ TDH39AA Audiometric Headset ¹ HDA280 ¹ IP 30 Insert Phones ¹ Eartone 5A 10 Ohm OEM ² Eartone 3a 10 Ohm ² Accessory kit Pen set/Audiogram UE10WCP1-050200SPA. External Power Supply Medical CE Approved APS3 Patient Signal Button ¹ Carrying Bag (TC608)

¹ Applied part according to IEC 60601-1

² This part is not certified according to IEC 60601-1



1.4 Warnings

Throughout this manual the following meaning of warnings, cautions and notices are used:



WARNING

The **WARNING** label identifies conditions or practices that may present danger to the patient and/or user.



CAUTION

The **CAUTION** label identifies conditions or practices that could result in damage to the equipment.

NOTICE

NOTICE is used to address practices not related to personal injury.





2 Unpacking and Installation

2.1 Unpacking and Inspection

Check box and contents for damage

When the instrument is received please check the shipping box for rough handling and damage. If the box is damaged it should be kept until the contents of the shipment have been checked mechanically and electrically. If the instrument is faulty please contact your local distributor. Keep the shipping material for the carrier's inspection and insurance claim.

Keep carton for future shipment

The AS608 comes in its own shipping carton, which is specially designed for the AS608. Please keep this carton. It will be needed if the instrument has to be returned for service.

If service is required, please contact your local distributor.

Reporting Imperfections

Inspect before connection

Prior to connecting the product it should once more be inspected for damage. All of the cabinet and the accessories should be checked visually for scratches and missing parts.

Report immediately any faults

Any missing part or malfunction should be reported immediately to the supplier of the instrument together with the invoice, serial number, and a detailed report of the problem. In the back of this manual you will find a "Return Report" where you can describe the problem.

Please use "Return Report"

Please realise that if the service engineer does not know what problem to look for he may not find it, so using the Return Report will be of great help to us and is your best guarantee that the correction of the problem will be to your satisfaction.







Storage

If you need to store the AS608 for a period, please ensure it is stored under the conditions specified in the section for technical specifications.



2.2 Marking

The following marking can be found on the instrument:

Symbol	Explanation
	Type B applied parts. Patient applied parts that are not conductive and can be immediately released from the patient.
	Refer to instruction manual
	WEEE (EU-directive) This symbol indicates that when the end-user wishes to discard this product, it must be sent to separate collection facilities for recovery and recycling. Failing to do so may endanger the environment.
	The CE-mark indicates that Interacoustics A/S meets the requirements of Annex II of the Medical Device Directive 93/42/EEC. TÜV Product Service, Identification No. 0123, has approved the quality system.
	Medical device
	Year of manufacture
	Do not re-use Parts like ear-tips and similar are for single use only



2.3 Important safety instructions

Read these instructions carefully and completely before using the product



If this apparatus is connected to one or more other devices with medical CE marking, to make up a system or pack, the CE marking is only valid also for the combination if the supplier has issued a declaration stating that the requirements in the Medical Device Directive article 12 are fulfilled for the combination.

2.3.1 Electrical system safety



When connecting the instrument to the computer, the following warnings must be observed:

This equipment is intended to be connected to other equipment thus forming a Medical Electrical System. External equipment intended for connection to signal input, signal output or other connectors shall comply with the relevant product standard e.g. IEC 60950-1 for IT equipment and the IEC 60601-series for medical electrical equipment. In addition, all such combinations – Medical Electrical Systems – shall comply with the safety requirements stated the general standard IEC 60601-1, edition 3, clause 16. Any equipment not complying with the leakage current requirements in IEC 60601-1 shall be kept outside the patient environment i.e. at least 1.5 m from the patient support or shall be supplied via a separation transformer to reduce the leakage currents. Any person who connects external equipment to signal input, signal output or other connectors has formed a Medical Electrical System and is therefore responsible for the system to comply with the requirements. If in doubt, contact qualified medical technician or your local representative. If the instrument is connected to a PC (IT equipment forming a system) ensure not to touch the patient while operating the PC.

A Separation Device (isolation device) is needed to isolate the equipment located outside the patient environment from the equipment located inside the patient environment. In particular such a Separation Device is required when a network connection is made. The requirement for the Separation Device is defined in IEC 60601-1 clause 16

2.3.2 Electrical safety



Do not modify this equipment without authorization of Interacoustics Do not disassemble or modify the product as this may impact on the safety and/or performance of the device. Refer servicing to qualified personnel.
For maximum electrical safety, turn off the power when it is left unused

The power plug shall be placed so it is easy to pull out the plug
Do not use any additional multiple socket-outlet or extension cord.
Do not use the equipment if it is showing visible signs of damage.

The instrument is not protected against ingress of water or other liquids. If any spillage occurs, check the instrument carefully before use or return for service

No part of the equipment can be serviced or maintained while in use with the patient.



2.3.3 Explosion hazards



Do NOT use in the presence of flammable gaseous mixtures. Users should consider the possibility of explosions or fire when using this device in close proximity to flammable anesthetic gases.

Do NOT use the instrument in a highly oxygen-enriched environment, such as a hyperbaric chamber, oxygen tent, etc.

Before cleaning make sure to disconnect power source.

2.3.4 Electromagnetic compatibility (EMC)



CAUTION

Although the instrument fulfills the relevant EMC requirements, precautions should be taken to avoid unnecessary exposure to electromagnetic fields, e.g., from mobile phones, etc. If the device is used adjacent to other equipment it must be observed that no mutual disturbance appears. Please also refer to the appendix regarding EMC.

Use of accessories, transducers and cables other than specified, with the exception of transducers and cables sold by Interacoustics or representatives, may result in increased emission or decreased immunity of the equipment. For a list of accessories, transducers and cables that fulfil the requirements please also refer to the appendix regarding EMC.

2.3.5 Cautions – General



CAUTION

If the system is not functioning properly, do not operate it until all necessary repairs are made and the unit is tested and calibrated for proper functioning in accordance with Interacoustics' specifications.

Do not drop or in any other way cause undue impact to this device. If the instrument is damaged, return it to the manufacturer for repair and/or calibration. Do not use the instrument if any damage is suspected.

This product and its components will perform reliably only when operated and maintained in accordance with the instructions contained in this manual, accompanying labels, and/or inserts. A defective product should not be used. Make sure all connections to external accessories are secured properly. Parts which may be broken or missing or are visibly worn, distorted, or contaminated should be replaced immediately with clean, genuine replacement parts manufactured by or available from Interacoustics.

Interacoustics will make available on request circuit diagrams, component part lists, descriptions, calibration instructions, or other information that will assist authorized service personnel to repair those parts of this instrument that are designated by Interacoustics as repairable by service personnel.

No parts of the equipment can be serviced or maintained while in use with the patient.



Connect only accessories purchased from Interacoustics to the instrument. Only accessories which have been stated by Interacoustics to be compatible are allowed to be connected to the device.

Never insert, or in any way use, the insert headset without a new clean and non-defective ear-tip. Always make sure that the foam or ear-tip is mounted correctly. Ear-tips and foam are for single use only.

The instrument is not intended for use in environments exposed to fluid spills.

Check calibration if any parts of the equipment are exposed to shock or rough handling.

Components marked for 'single use' are intended for a single patient during a single procedure, and there is a risk of contamination if the component is re-used. Components marked for 'single use' are not intended to be reprocessed.

Use only transducers calibrated with the actual instrument.

In case of a serious incident with serious health impact for the patient or user Interacoustics shall be informed. Beside that the competent authority in patient's home country shall be informed. Interacoustics has a vigilance system to help with this.

2.3.6 Environmental factors



CAUTION

Storage outside temperature range as specified in Section 2.1 may cause permanent damage to the instrument and its accessories.

Do not use the device in the presence of fluid that can come into contact with any of the electronic components or wiring. Should the user suspect fluids have contacted the system components or accessories, the unit should not be used until deemed safe by an authorized service technician.

Do not place the instrument next to a heat source of any kind and allow sufficient space around the instrument to ensure proper ventilation.

2.3.7 Disposal

NOTICE

To prevent system faults, take appropriate precautions to avoid PC viruses and similar.

Within the European Union, it is illegal to dispose of electric and electronic items in unsorted municipal waste. Electric and electronic waste may contain hazardous substances and therefore has to be collected separately. Such products will be marked with the crossed-out wheeled bin symbol, shown below.



The cooperation of the user is important in order to ensure a high level of reuse and recycling of electric and electronic waste. Failing to recycle such waste products in an appropriate way may endanger the environment and consequently the health of human beings.

Outside the European Union, local regulations should be followed when disposing of the product after end of life.

Be sure to use only stimulation intensities, which will be acceptable for the patient.

The transducers (headphones, bone conductor, etc.) supplied with the instrument are calibrated to this instrument - exchange of transducers require a recalibration.

It is recommended that parts which are in direct contact with the patient (e.g. earphone cushions) are subjected to standard disinfecting procedure between patients. This includes physically cleaning and use of a recognised disinfectant. Individual manufacturer's instruction should be followed for use of this disinfecting agent to provide an appropriated level of cleanliness.

Please note that the CE Marking is only legal if this Instruction is translated into the national language of the user no later than at the delivery to him, if the national legislation demands a text in the national language according to MDD article 4.4.

2.4 Malfunction



In the event of a product malfunction, it is important to protect patients, users, and other persons against harm. Therefore, if the product has caused, or potentially could cause such harm, it must be quarantined immediately.

Both harmful and harmless malfunctions, related to the product itself or to its use, must immediately be reported to the distributor where the product was acquired. Please remember to include as many details as possible e.g. the type of harm, serial number of the product, software version, connected accessories and any other relevant information.

In case of death or serious incident in relation to the use of the device, the incident must immediately be reported to Interacoustics and the local national competent authority.



3 Getting Started - Setup and Installation

3.1 AS608 - Connection Panel Dictionary

Position:	Symbol:	Function:
1	Battery	Battery holder for three batteries AA/LR6 (Alkaline).
2	Power / USB	Socket for external power supply ASA30M
3	Patient Resp.	Socket for patient response switch APS3.
4	Right	Socket for right headphone DD65.
5	Left	Socket for left headphone DD65.

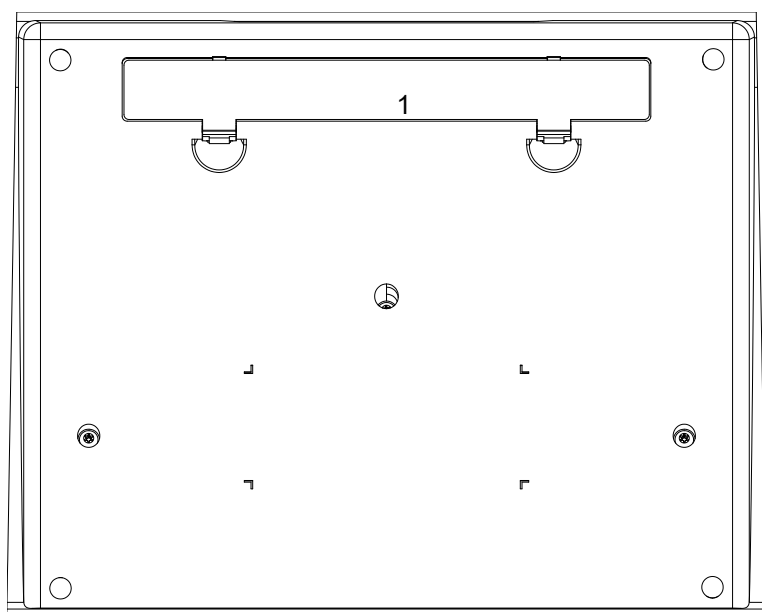
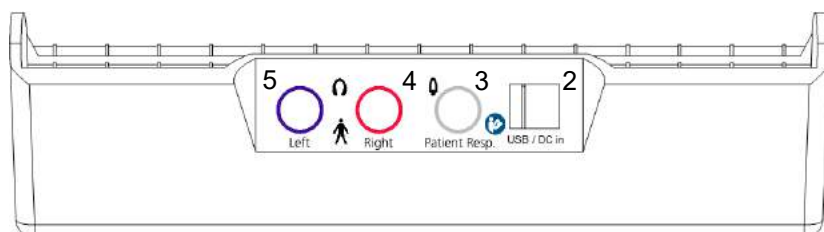



3.2 AS608 - Operation Panel Dictionary

Position:	Symbol:	Function:
F1	Right	Selects Right headphone. L/R toggle on AS608e
F2	Left	Selects Left headphone on 608 / Store threshold on AS608e
F3	Man / Pulse	Select Man to have the tone presented when Tone Switch is activated. Select Pulse to present pulsing tones when the Tone Switch is activated.
F4	Pure Tone / Warble	Select Pure tone or Warble tone as stimulus.
1	Frequency Hz	Selects stimulus frequency.
2	HL dB	Adjustment of Intensity
3	Tone Switch	Presents stimulus.
A	Tone	Indicates presentation.
B	Response	Indicates response from patient.
C	External Power / Battery status	Indication of external power supply / battery status.

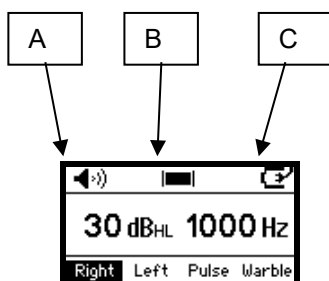
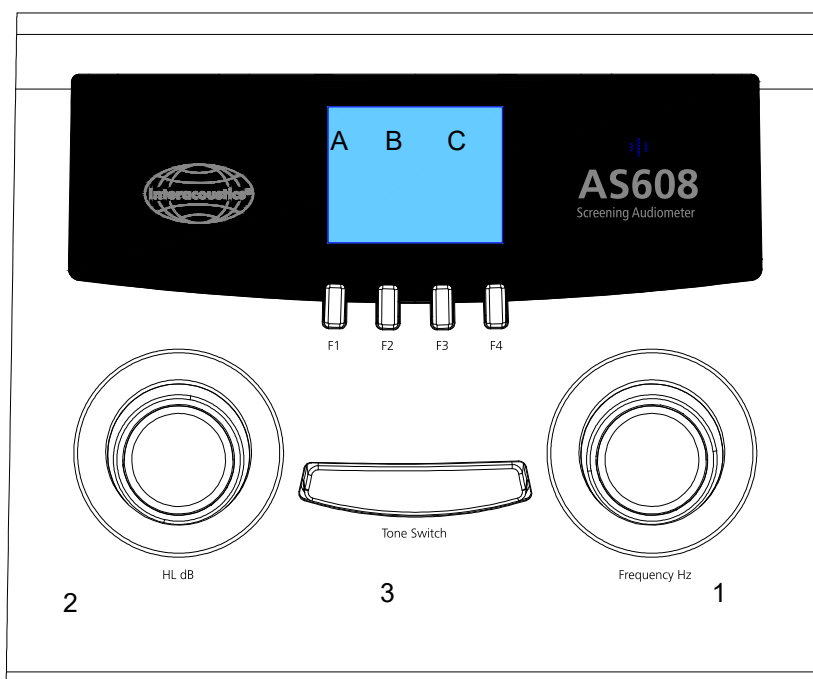



3.3 Air Conduction

Hearing threshold levels can be determined by presenting test signals to the test subject with the included earphones (air conduction – AC). The purpose of AC audiometry is to establish the hearing sensitivity at various frequencies. The test can specify the AC loss but cannot distinguish between abnormality in the conductive mechanism and sensor neural mechanism.

Headset Placement:

Remove eye glasses and ear rings if possible and position the headband directly over the top of the head. Place the rubber cushions so that the diaphragms are aimed directly at the opening into the ear canal. Pull down the yokes of the phones and adjust for tight fit. If the cushions are not tight to the ears, the test results may be false at lower frequencies.

Background Noise:

Background noise can also produce false test results, especially at lower frequencies. If necessary, the DD65 can be equipped with noise excluding enclosures. Please contact the distributor for more information.

Instruction of Subject:

Prior to hearing threshold level measurements, the following instructions should be given. "You will now hear a variety of pitches with various loudness levels. Please push the signal button when you hear a tone and release the button when you no longer hear it. If not using the response button, ask the patient to "raise their left or right hand when you hear the tone in the left or right ear".

Threshold Determination:

The test normally starts at 1000 Hz on the patient's better ear with the L/R switch adjusted accordingly.

Familiarization:

Present a tone at 1000 Hz which can easily be perceived (i.e. 50dB) If necessary, increase with steps of 10 dB until the tone is clearly perceived.

Threshold Determination:

The hearing threshold is defined as the lowest level at which more than half of the stimuli are heard. This threshold is found by the following procedure.

- 1) Present a tone which is 10 dB lower than the level at which familiarization was finished.
- 2) Decrease the level in steps of 10 dB until response fails.
- 3) Increase the level in steps of 5 dB until the subject responds again.
- 4) Repeat 2) and 3) two or three times until the threshold appears at the same level.

The time intervals in between the stimuli should be varied to prevent the subject to react on the rhythm.

- 5) Change to the next frequency and repeat the procedure until all frequencies are measured. Repeat the procedure at 1000 Hz. If the difference to the previously found threshold is then 5dB or less go to the other ear. If the difference is 10 dB or higher, repeat the test at the other frequencies, until agreement to 5 dB or less has been obtained.
- 6) Proceed until both ears have been tested.

Screening Procedure:

It is common to test at one dB level for preliminary hearing screenings as is often done in schools and primary practice clinics. In this instance you would follow the same familiarization and instruction procedures as stated above, but present a single dB level (i.e. 25dB) at just 4 frequencies (500, 1000, 2000 & 4000 Hz) in each ear. In this instance, you simply record a response or no response to the single tone presentations at each frequency.

**Auto Threshold:**

In addition to traditional manual testing, the AS608e incorporates a Hughson Westlake patient controlled automatic threshold test complying with ISO 8253. When the test is completed the results are easily recalled from the internal memory of the AS608e and transferred to the Diagnostic Suite PC software and stored in OtoAccess® or Noah.

Hughson Westlake is an automatic pure tone test procedure. Threshold is defined as 2 out of 3 (or 3 out of 5) correct responses at a certain level in a 5 dB increase and 10 dB decrease test procedure. The Hughson Westlake is used to obtain pure tone thresholds automatically.

Talk Forward

The Talk Forward function makes the AS608e easy to work with particularly in sound booth installations.

3.4 Power Up and Power Off

To turn on the audiometer press the Tone Switch (3) button. To power off the audiometer hold down the two rotary wheel buttons, 1) and 2), simultaneously for a few seconds. The audiometer will also automatically power off after 1, 2, 3, 4 or 5 minutes depending on the settings (see next section).

3.5 Pure Tone Presentation

1) Select desired frequency with the "Frequency" button

2) Select desired intensity with the HL dB.

3) Present tone by touching Tone Switch. An indication will be on Display (see below).

F1) On AS608: Select the Right ear. On AS608e: Toggle between Right and Left.

F2) On AS608: Select the Left ear. On AS608e: Store threshold.

F3) Manual or Pulse:

Manual: Manual Tone presentation as long as the Tone Switch is activated.

Pulse: Pulsing Tone will be presented as long as the Tone Switch is activated.

F4) Pure Tone or Warble:

If Tone is selected pure tones will be presented to the subject when the Tone Switch is activated.

If Warble is selected warble tones will be presented to the subject when the Tone Switch is activated.



3.6 AS608e Special Functions:

Talk Forward: On the AS608e Talk Forward is activated by holding down the HL db (3) rotary wheel.

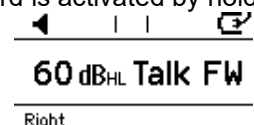

While holding down the Tone Switch button (3), the talk forward level can be adjusted.

The following F-key functionalities can be accessed by pressing the frequency rotary wheel (1):

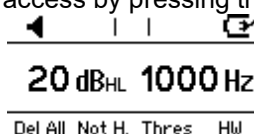

F1: Delete all thresholds stored in the internal memory of the AS608e.

F2: Store a Not Heard threshold point.

F3: Display the L/R thresholds stored in the internal memory of the AS608e.

	Thresholds			
Hz	125	250	500	750
R	20	20	20	20
L	20	20	20	20

Del All ← → Back

F4: Start the Hughson Westlake (HW) automatic test procedure. Please refer to the next chapter for instructions about how to setup the HW test.

3.7 Display:

A) **Tone:** A tone presentation indicator is provided in the top left corner of the display header.



B) **Response:** When using the APS3 response button, a response is indicated in the middle of display header.



C) **Power On or Battery status:** The power status of the AS608/AS608e is indicated in the top right corner of the display header.

The icon will change depending on whether the instrument is powered via an external source (power supply or USB connection to computer) or batteries.

When powered by batteries, the battery icon will change depending on the battery power level. When batteries are running low the display will read Low Battery and flash.

The Power Off settings of the instrument can be adjusted at different time intervals or set to never power off – please see Setup section for details.

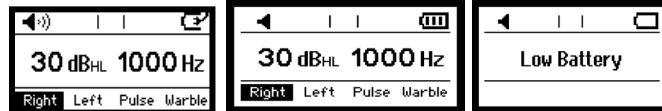

3.8 Setup Menu of AS608/AS608e

To access the AS608/AS608e setup menu press F1 and F4 simultaneously for 2-3 seconds.

F1	Change setting
F2	Browse up in the setup menu
F3	Browse down in the setup menu
F4	Save settings and Back to previous screen display – see below for details

Power up Tone

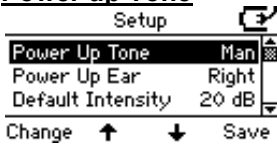

Press Change to toggle between Manual and Reverse.

Power up Ear

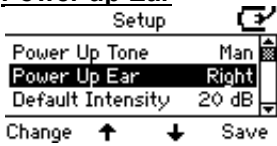

Press Change to toggle between Right and Left ear as the default ear for Power Up

Default Intensity

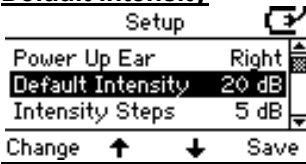

The default intensity when changing ear side. Choose between: Off, -10dB, -5dB, 0dB, 5dB, 10dB, 15dB, 20dB, 25dB, 30dB, 35dB, 40dB, 45dB and 50dB.

Intensity Steps

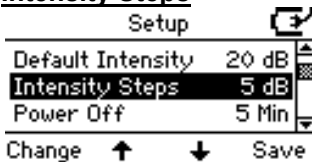

Choose Between: 1 dB and 5 dB.



Power Off setting

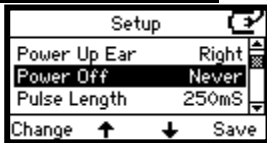

Press Change to toggle between Never, 1, 2, 3, 4 or 5 minutes.

Pulse Length

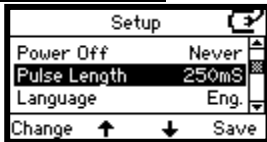

Press Change to toggle between 250msec and 500msec.

Language

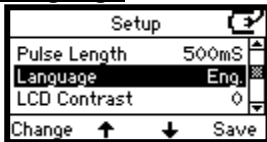

Press Change to toggle between English, German, Spanish and French.

LCD Contrast.

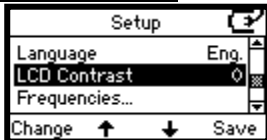

Press Change to toggle between settings ranging from 0 (very bright) to 6 (very dark).

HW Test... (only on AS608e)

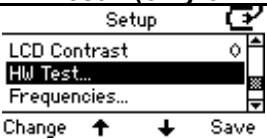

Press Change to go to the Hughson Westlake (HW) automatic test procedure setup.

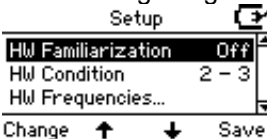

Press Change to toggle between Familiarization On/Off. Familiarization is used to train the patient.

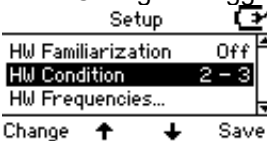



Press Change to toggle between “2 correct out of 3 answers” and “3 correct out of 5 answers”. The conditions used before going to the next frequency.

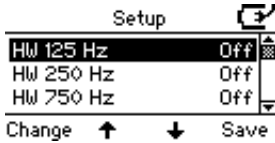

Select the frequencies to include in the HW test. Press Change to toggle between frequencies On/Off.

Press Save to return to the main HW setup menu.

HW Frequencies



Press Change to access the default frequency range from 125Hz to 8 kHz for daily operation.

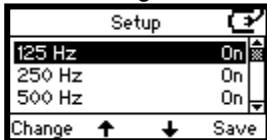

7 frequencies are available to change: 125, 250, 750, 1,500, 3,000, 6,000 and 8,000.

Press Change to toggle between On or Off.

HW on time

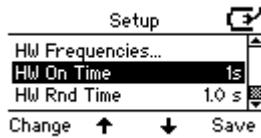

Press Change to set the stimulus on time to 1 or 2 seconds.

HW random time off

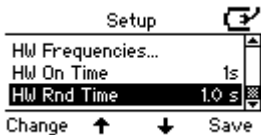

Press Change to set the random time. The random time can be set between 0 and 1.6 seconds.

HW lower limit



Press Change to set the lower limit and determine when to move on to the next frequency. The lower limit can be set between -10 and 20 dB.



Press Save to return to the main setup menu.

License.

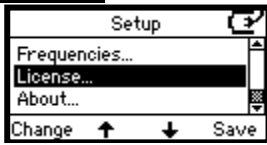

Press Change to access the license key of the AS608/AS608e instrument.



Press Change to enter and/or modify the license key of the AS608/AS608e instrument.

Use button 2 to change the letter and button 1 to move the cursor

Press Save to return to the main setup menu.

About



Press Change to access the information in the About section.



Press Back to return to the main setup menu.

Press Save to return to measurement screen of the AS608/AS608e.



3.9 About Diagnostic Suite

Should you go to Menu > Help > About then you will see the below window. This is the area of the software where you can manage license keys and check your Suite, Firmware and Build Versions.

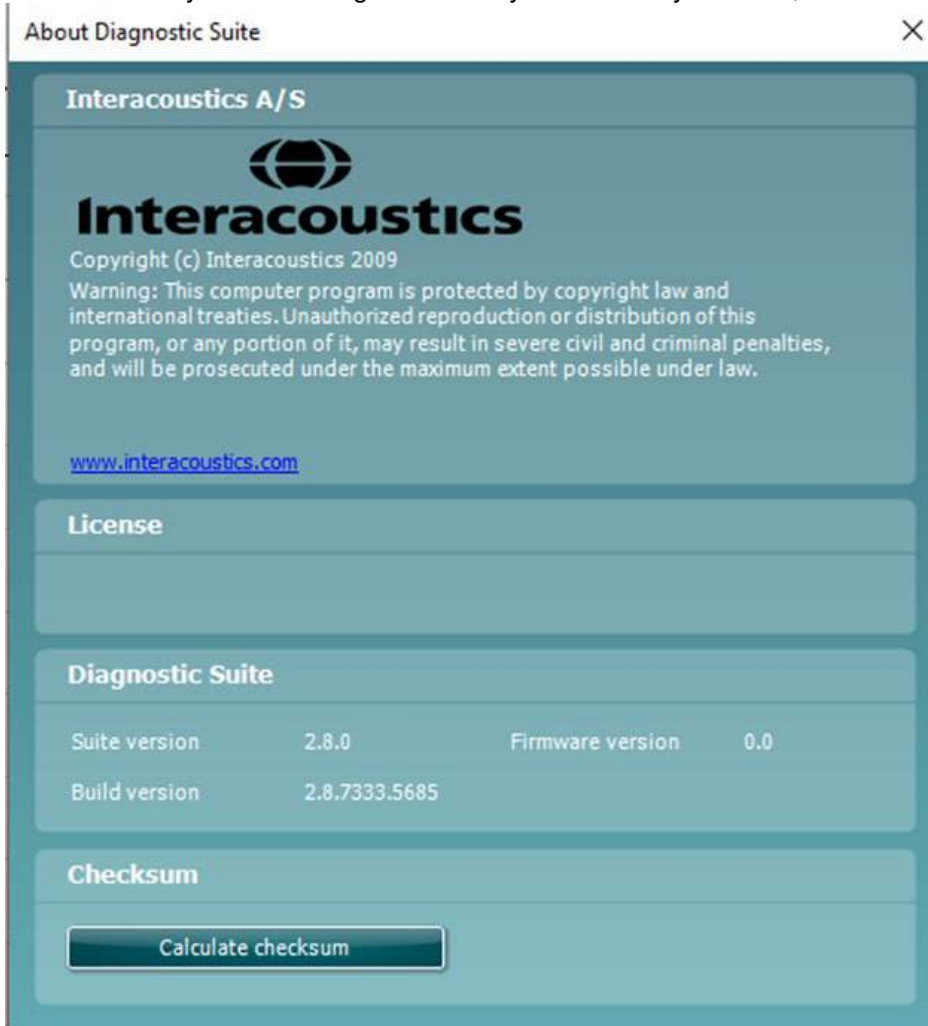

Also in this window you will find the Checksum section which is a feature designed to help you identify the integrity of the software. It works by checking the file and folder content of your software version. This is using an SHA-256 algorithm.

On opening the checksum you will see a string of characters and numbers, you can copy this by double clicking on it.



4 Care and Maintenance

4.1 General Maintenance Procedures



The performance and safety of the instrument will be kept if the following recommendations for care and maintenance are observed:

It is recommended to let the instrument go through at least one annual evaluation, to ensure that the acoustical, electrical and mechanical properties are correct. This should be made by an experienced workshop in order to guarantee proper service and repair.

No parts of the equipment can be serviced or maintained while in use with the patient.

Before the connection to the mains, be sure that the local mains voltage corresponds to the voltage labelled on the instrument.

Observe that no damage is present on the insulation of the mains cable or the connectors and that it is not exposed to any kind of mechanical load, which could involve damage.

For maximum electrical safety, turn off the power from a mains powered instrument when it is left unused.

Do not place the instrument next to a heat source of any kind, and allow sufficient space around the instrument to ensure proper ventilation.

To ensure the reliability of the instrument, periodic biological measurements should be performed on a person with known data. This person could be the operator him/herself.

If the surface of the instrument or parts of it is dirty, it can be cleaned using a soft cloth moistened with a mild solution of water and dish washing cleaner or similar. The use of organic solvents and aromatic oils must be avoided. Always disconnect the mains plug during the cleaning process, and be careful that no fluid is entering the inside of the instrument or the accessories.

After each examination of a patient, proper cleaning must ensure that there is no contamination on the parts in connection with patients. General precautions must be observed to prevent transmission of disease from one patient to another. If the ear cushions or ear tips are contaminated, it is strongly recommended to remove them from the transducer before they are cleaned. Frequent cleaning using water may be used, but periodic use of a mild disinfectant may also be used. The use of organic solvents and aromatic oils must be avoided.

Great care should be exercised by the handling of earphones and other transducers, as mechanical shock may cause change of calibration.



4.2 How to clean Interacoustics Products

If the surface of the instrument or parts of it are contaminated, it can be cleaned using a soft cloth moistened with a mild solution of water and dish washing cleaner or similar. The use of organic solvents and aromatic oils must be avoided. Always disconnect the USB cable during the cleaning process, and be careful that no fluid is entering the inside of the instrument or the accessories.



- Before cleaning always switch off and disconnect from power
- Use a soft cloth lightly dampened with cleaning solution to clean all exposed surfaces
- Do not allow liquid to come in contact with the metal parts inside the earphones / headphones
- Do not autoclave, sterilize or immerse the instrument or accessory in any fluid
- Do not use hard or pointed objects to clean any part of the instrument or accessory
- Do not let parts that have been in contact with fluids dry before cleaning
- Rubber ear-tips or foam ear-tips are single use components

Recommended cleaning and disinfection solutions:

- Warm water with mild, nonabrasive cleaning solution (soap)

Procedure:

- Clean the instrument by wiping outer case with a lint free cloth lightly dampened in cleaning solution.
- Clean cushions and patient hand switch and other parts with a lint free cloth lightly dampened in cleaning solution.
- Make sure not to get moisture in the speaker portion of the earphones and similar parts

4.1 Concerning Repair

Interacoustics is only considered to be responsible for the validity of the CE marking, effects on safety, reliability and performance of the equipment if:

1. assembly operations, extensions, readjustments, modifications or repairs are carried out by authorised persons,
2. a 1 year service interval is maintained
3. the electrical installation of the relevant room complies with the appropriate requirements, and
4. the equipment is used by authorised personnel in accordance with the documentation supplied by Interacoustics.

The customer shall reach out to the local distributor to determine the service/repair possibilities including onsite service/repair. It is important that the customer (through local distributor) fills out the **RETURN REPORT** every time when the component/product is sent for service/repair to Interacoustics.

4.3 Warranty

INTERACOUSTICS warrants that:

- The AS608 is free from defects in material and workmanship under normal use and service for a period of 12 months from the date of delivery by Interacoustics to the first purchaser.
- Accessories are free from defects in material and workmanship under normal use and service for a period of ninety (90) days from the date of delivery by Interacoustics to the first purchaser.

If any product requires service during the applicable warranty period, the purchaser should communicate directly with the local Interacoustics service centre to determine the appropriate repair facility. Repair or replacement will be carried out at Interacoustics' expense, subject to the terms of this warranty. The product requiring service should be returned promptly, properly packed, and postage prepaid. Loss or damage in return shipment to Interacoustics shall be at purchaser's risk.



In no event shall Interacoustics be liable for any incidental, indirect or consequential damages in connection with the purchase or use of any Interacoustics product.

This shall apply solely to the original purchaser. This warranty shall not apply to any subsequent owner or holder of the product. Furthermore, this warranty shall not apply to, and Interacoustics shall not be responsible for, any loss arising in connection with the purchase or use of any Interacoustics product that has been:

- repaired by anyone other than an authorized Interacoustics service representative;
- altered in any way so as, in Interacoustics judgement, to affect its stability or reliability;
- subject to misuse or negligence or accident, or which has had the serial or lot number altered, effaced or removed; or
- improperly maintained or used in any manner other than in accordance with the instructions furnished by Interacoustics.

This warranty is in lieu of all other warranties, express or implied, and of all other obligations or liabilities of Interacoustics, and Interacoustics does not give or grant, directly or indirectly, the authority to any representative or other person to assume on behalf of Interacoustics any other liability in connection with the sale of Interacoustics products.

INTERACOUSTICS DISCLAIMS ALL OTHER WARRANTIES, EXPRESSED OR IMPLIED, INCLUDING ANY WARRANTY OF MERCHANTABILITY OR FOR FUNCTION OF FITNESS FOR A PARTICULAR PURPOSE OR APPLICATION.





5 General Technical Specifications

Standards:

Meets or exceeds EN 60645-1 type 4 and ANSI S3.6
Safety Standard: EN 60601-1, Class II, type B.
EMC: EN 60601-1-2

Calibration:

PTB/DTU report 2009 (DD45)
ISO 389-1 1998, ANSI S3.6-2010 (TDH39)
ISO 389-2 1994, ANSI S3.6-2010 (E.A.R Tone 3A/5A)
ISO 389-2 (EAR-Tone 3A and 5A)
PTB Report 1.61-64/04 (HDA280).
PTB Report 1.61-4039503/09 (DD65)

Medical CE-mark:



The CE-mark indicates that Interacoustics A/S meets the requirements of Annex II of the Medical Device Directive 93/42/EEC. TÜV Product Service, Identification No. 0123, has approved the quality system.

Frequencies and Intensities:

Freq. Hz.	AC, dB HL
125	70
250	90
500	100
750	100
1000	100
1500	100
2000	100
3000	100
4000	100
6000	100
8000	90

Inputs: Tone
Warble Tone $\pm 5\%$, 5Hz (true sine wave frequency modulation).

Outputs: Left and Right.

Tone Presentation:

Manual or Reverse (chosen in Setup Menu).
Multiple pulses 250 or 500msec (chosen in Setup Menu.).

Talk Forward: Built in talk forward microphone. 0-110dB SPL. Continuously adjustable on operation panel.

Auto Threshold: Patient controlled Hughson Westlake procedure according to ISO 8253-1.

Store Function: Soft key (F-key) store button and internal memory for AC L/R. Stored Measurements can be viewed on the build in display or transferred to the PC using the Diagnostic Suite Audiogram software module.



PC Software / Interface: The Diagnostic Suite PC software with advanced reporting and printing features. OtoAccess® and Noah compatible.

Distortion:

0,3% typical at full intensity.
1% maximum at full intensity.

Rise/fall Times:

35 msec. typically.

Display Header Indicators:

Tone On.
Patient Response.
Power/Battery Status

Batteries:

3 AA size, Alkaline type.
Automatic battery on/off switching.
Automatic battery status indication.

Battery life:

Standby: 6 months
Tone presentations: 70.000

External Power Supply (through USB connector):

Accepts 5 VDC – minimum 150 mA
The recommended UE10WCP1-050200SPA (5 Volt, 2 A) is approved with the AS608/AS608e.
UE10WCP1-050220SPA: Input 100-240VAC 50/60 Hz, 500 mA, Output 5.0 V 2.0 A. (Class II)

Construction:

Plastic cabinet.

Dimensions:

WxDxH: 22.5 x 18 x 5.5 cm / 8,9 x 7.1 x 2,2 inches

Weight: 1.0 kg – including batteries and headset.

1.6 kg – including TC608 carrying bag incl. peltor noise reducing headset, audiogram charts etc.

Operating Environment:

Temperature: 15-35°C/59-95°F.
Relative Humidity: 30-90 %.
Air pressure 98 kPa to 104 kPa
Maximum altitude: 2000 m / 6561 ft above sea level

Storage Environment:

Temperature: 0-50°C/32-122°F.
Relative Humidity: 10-95 %.

Transport Environment:

Temperature: -20-50°C/-4-122°F.
Relative Humidity: 10-95 %.

Computer requirements:

Must comply with IEC 60950-1.
Equipped with a USB connection.



5.1 Reference Equivalent Threshold Values for transducers

Calibration standard	TDH39 ISO 389-1: 1998	TDH39 ANSI S3.6: 2004	DD65 v2 ANSI S3.6 208	DD45 PTB Test report 1.61- 4039503/09	HDA280 PTB	Insert EARtone EAR3/EAR5 ISO389-2: 1994
Coupler standard	IEC60318-3: 1998	ANSI 9A	IEC60318-1	IEC60318-3: 1998	IEC60318-3: 1998	60318-5: 2006
Frequency [Hz]	[dB re. 20 µPa]	[dB re. 20 µPa]	[dB re. 20 µPa]	[dB re. 20 µPa]	[dB re. 20 µPa]	[dB re. 20 µPa]
125	45.0	45.0	30,5	47.5	38.5	26.0
250	25.5	25.5	17	27.0	25.0	14.0
500	11.5	11.5	8	13.0	13.0	5.5
750	7.5	8.0	5,5	6.5	9.0	2.0
1000	7.0	7.0	4,5	6.0	7.5	0.0
1500	6.5	6.5	2,5	8.0	9.5	2.0
2000	9.0	9.0	2,5	8.0	8.0	3.0
3000	10.0	10.0	2	8.0	6.5	3.5
4000	9.5	9.5	9,5	9.0	9.5	5.5
6000	15.5	15.5	21	20.5	19.0	2.0
8000	13.0	13.0	21	12.0	18.0	0.0

5.2 Maximum hearing level settings provided at each test frequency

Frequency Hz	Air Conduction TDH39	Air Conduction DD65 v2	Air Conduction DD45	Air Conduction HDA280	Air Conduction EARtone 3A	Air Conduction EARtone 5A
125	70	70	70	70	70	70
250	90	90	90	90	90	90
500	100	100	100	100	100	100
750	100	100	100	100	100	100
1000	100	100	100	100	100	100
1500	100	100	100	100	100	100
2000	100	100	100	100	100	100
3000	100	100	100	100	100	100
4000	100	100	100	100	100	100
6000	100	85	100	90	95	95
8000	90	70	90	80	70	80



5.3 Pin Assignments

Inputs	Connector type	Electrical properties
Power	USB plug	5V
USB 1.1 comm.	USB plug	90Ω Impedance
Patient response	Jack, 6.3mm stereo	Accepts both mono and stereo 6.3mm jack Uses sleeve + tip or ring + tip for response. Tip 3.3V through 1KΩ. Impedance total 6,75KΩ for stereo, 6,25KΩ for mono.

Outputs:

Phones, Left/Right	Jack, 6.3mm mono	Voltage: Up to 3V rms. by 10Ω load Min. load impedance: 5Ω Output impedance: 0,5Ω Connection: Uses sleeve + tip mono 6.3mm jack.
--------------------	------------------	---

Other electrical specifications:

Warble 5 Hz sine, ±5% modulation

5.4 Electromagnetic Compatibility (EMC)

See Appendix in English in the back of the manual.

Return Report – Form 001



Opr. dato: 2014-03-07 af: EC Rev. dato: af: MSt Rev. nr.: 4

Company: _____

Address: _____

Phone: _____

Fax or e-mail: _____

Address

10393 West 70th Street
Prairie
MN 55344
USA

Phone

(+1) 800 947 6334

Fax

(+1) 952 903 4200

E-mail

rmd@interacoustics-us.com

Contact person: _____ Date: _____

Following item is reported to be:

- returned to INTERACOUSTICS for: repair, exchange, other: _____
- defective as described below with request of assistance
- repaired locally as described below
- showing general problems as described below

Item: _____ **Type:** _____ **Quantity:** _____
Serial No.: _____ Supplied by: _____
Included parts: _____

Important! - Accessories used together with the item must be included if returned (e.g. external power supply, headsets, transducers and couplers).

Description of problem or the performed local repair:

Returned according to agreement with: Interacoustics, Other : _____

Date : _____ Person : _____

Please provide e-mail address or fax No. to whom Interacoustics may confirm reception of the returned goods:

The above mentioned item is reported to be dangerous to patient or user ¹

In order to ensure instant and effective treatment of returned goods, it is important that this form is filled in and placed together with the item.
Please note that the goods must be carefully packed, preferably in original packing, in order to avoid damage during transport. (Packing material may be ordered from Interacoustics)

¹ EC Medical Device Directive rules require immediate report to be sent, if the device by malfunction deterioration of performance or characteristics and/or by inadequacy in labelling or instructions for use, has caused or could have caused death or serious deterioration of health to patient or user. Page 1 of 1