

Operation Manual

Dedicated Test Chamber TBS25



***Valid from serial no. 10xxxx
80615202 – version 11/2008***

Table of Contents

Table of Contents	1
Precautions	2
Warranty	4
Installation	6
Placement of TBS25.....	6
Connection to Affinity ^{2.0} or Equinox ^{2.0}	7
Connection to other Analyzers.....	9
Calibration.....	10
Daily Use.....	11
General Procedure	11
Positioning of BTE Hearing Aids	11
Positioning of Directional Hearing Aids	12
Positioning of ITE Hearing Aids.....	12
Positioning of Large devices.....	13
Technical Considerations	14
Noise Rejection	14
Distortion	16
Free Field Conditions	16
Frequency Response	18
Measurement Circle	20
Open or Closed Lid.....	20
Technical Specifications.....	22
Dimensions of Test bed.....	24
Connection Panel	25
Technical specifications for built-in loop.....	26
Using Internal Wiring for Standard Microphone	28
Unpacking / Inspection	29
Contents of Shipment	29
Reporting Imperfections	30
Trouble Shooting	31
Appendix A: Service Kit	33
Appendix B: General Maintenance Procedures.....	37

Precautions

Following the ANSI recommendations (American National Standards Institute) for safety notes, specific passages of this instruction manual are clearly marked as safety notes.

	WARNING indicates a hazardous situation which, if not avoided, could result in death or serious injury.
	CAUTION , used with the safety alert symbol, indicates a hazardous situation which, if not avoided, could result in minor or moderate injury.
	NOTICE is used to address practices not related to personal injury
	CAUTION , used without the safety alert symbol, is used to address practices not related to personal injury.

 Attention must be paid to the operation of closing the lid, as the pressure from the lid on the back part of the box is high enough to give rise to injury. Be sure that no fingers or hands are placed in this area while closing the lid..







If this apparatus is connected to one or more other devices with medical CE marking, to make up a system or pack, the CE marking is only valid also for the combination if the supplier has issued a declaration stating that the requirements in the Medical Device Directive article 12 are fulfilled for the combination.

NOTICE

Within the European Union it is illegal to dispose electric and electronic waste as unsorted municipal waste. Electric and electronic waste may contain hazardous substances and therefore has to be collected separately. Such products will be marked with the crossed-out wheeled bin shown below. The cooperation of the user is important in order to ensure a high level of reuse and recycling of electric and electronic waste. Failing to recycle such waste products in an appropriate way may endanger the environment and consequently the health of human beings.



Explanation to symbols which can be found on the instrument:

I	On (Power: connection to the mains)
O	Off (Power: disconnection from the mains)
~	Alternating current
	Fuse
	Ground
	Dangerous voltage
	See explanation in manual
	Type B equipment

Warranty

INTERACOUSTICS warrants that:

- The TBS25 is free from defects in material and workmanship under normal use and service for a period of 24 months from the date of delivery by Interacoustics to the first purchaser.
- Accessories are free from defects in material and workmanship under normal use and service for a period of ninety (90) days from the date of delivery by Interacoustics to the first purchaser.

If any product requires service during the applicable warranty period, the purchaser should communicate directly with the local Interacoustics service centre to determine the appropriate repair facility. Repair or replacement will be carried out at Interacoustics' expense, subject to the terms of this warranty. The product requiring service should be returned promptly, properly packed, and postage prepaid. Loss or damage in return shipment to Interacoustics shall be at purchaser's risk.

In no event shall Interacoustics be liable for any incidental, indirect or consequential damages in connection with the purchase or use of any Interacoustics product.

This shall apply solely to the original purchaser. This warranty shall not apply to any subsequent owner or holder of the product. Furthermore, this warranty shall not apply to, and Interacoustics shall not be responsible for, any loss arising in connection with the purchase or use of any Interacoustics product that has been:

- repaired by anyone other than an authorized Interacoustics service representative;
 - altered in any way so as, in Interacoustics judgement, to affect its stability or reliability;
 - subject to misuse or negligence or accident, or which has had the serial or lot number altered, effaced or removed;
- or

- improperly maintained or used in any manner other than in accordance with the instructions furnished by Interacoustics.

This warranty is in lieu of all other warranties, express or implied, and of all other obligations or liabilities of Interacoustics, and Interacoustics does not give or grant, directly or indirectly, the authority to any representative or other person to assume on behalf of Interacoustics any other liability in connection with the sale of Interacoustics products.

INTERACOUSTICS DISCLAIMS ALL OTHER WARRANTIES, EXPRESSED OR IMPLIED, INCLUDING ANY WARRANTY OF MERCHANTABILITY OR FOR FUNCTION OF FITNESS FOR A PARTICULAR PURPOSE OR APPLICATION.

Installation

Placement of TBS25

When placing the TBS25 several points must be considered:

Place for max. convenience

When deciding where to place the TBS25 maximum convenience for the operator should be considered

Place on stable surface.

The table or stand used must provide an absolutely stable support for the TBS25

If noise enters box

The noise rejection capabilities of the TBS25 are sufficient to work satisfactorily under most conditions. However, if problems arise please observe the following:

- In normal rooms noise at specific frequencies may change dramatically with position. For this reason alternative positioning of TBS25 should be checked.
- Noise travelling through the table on which the TBS25 is placed may enter the box, even though placed on the mounting mat which has some noise insulation effect. Try to use a different table and/or more heavy duty mounting mat for improved noise insulation.

Connection to Affinity^{2.0} or Equinox^{2.0}

The TBS25 is delivered with the 80417101 cable kit for TBS25-Affinity and includes:

1. 70856 Base for reference microphone
2. 70829 2.5 mm to 6.3 mm cables, 3 pcs.
3. 70812 Test box connection cable for speaker
4. 70881 Cable for test box loop



The cables are to be placed this way in the Affinity:



The cables are to be placed this way in the TBS25:



The reference microphone should be placed in one of the two holes:



Connection to other Analyzers

Jacks may be used for any device

The mini jack connectors are all fully wired three pole types and may be used to make connection from hearing aids or microphones inside the TBS25 to any relevant device outside the TBS25.

Cables may be entered through rubber duct on the shoulder

If you do not want to use the built-in jacks it is possible to let cables enter the TBS25 through the rubber area on the left-hand side of the box. Be sure not to have the cable bending out and reach the wooden area as this will probably ruin the cable when the lid is closed. See below sketch for correct placement of cables.

Cable position may be secured by use of tape or by making a cut into the rubber with a Stanley knife and then press the cable into this passage.

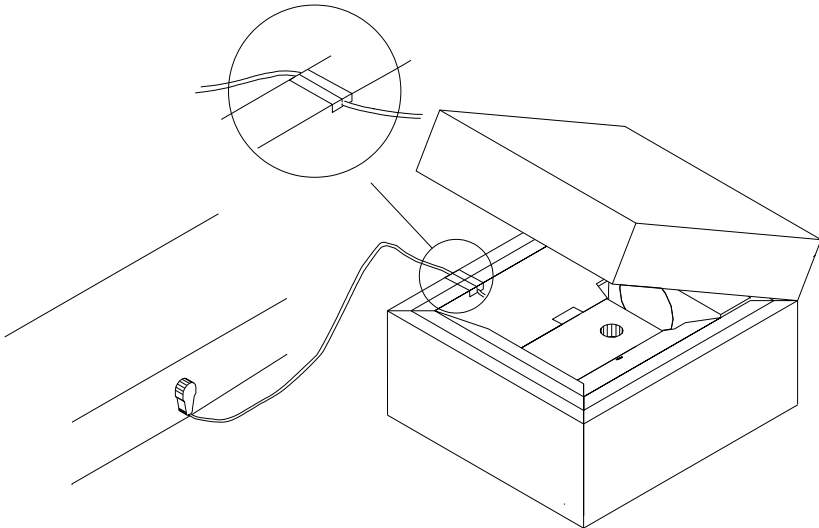

Drilling any holes in the box should be avoided as external noise may thus find a passage into the box.

Calibration

No re-calibration is needed with Affinity^{2.0} or Equinox^{2.0}

When the TBS25 is used with MS25 or MS40 the reference microphone as well as the coupler is those used and calibrated to the analyzer. For this reason no re-calibration is needed.

Telecoil is identical to Affinity^{2.0} or Equinox^{2.0}

The telecoil in the TBS25 is identical in design to that of the MS25/MS40 and therefore normally no re-calibration is needed.

Calibration needed for other analyzers

When the TBS25 is used with other analyzers, please apply calibration procedures as outlined for these instruments.

Daily Use

General Procedure

1. Place the device to be tested in the test space in accordance with the sketch below.
2. Place the reference microphone 5mm from the hearing aid microphone (for directional microphones this distance should be 12mm).
3. Close the lid. Clockwise rotation as well as counter clockwise rotation of the handle will secure the lid. Do not touch the box during testing.
4. Run the test in accordance with the procedures outlined for the connected analyzer.
5. When testing telecoil function remove the blue foam indicating the test point and place the coupler in the resulting hole so the hearing aid is hanging by the silicon tube and thus positioned as being worn by a patient. Rotate the coupler for maximum output from the telecoil.

Positioning of BTE Hearing Aids

Place the hearing aid to be tested in accordance with this sketch:

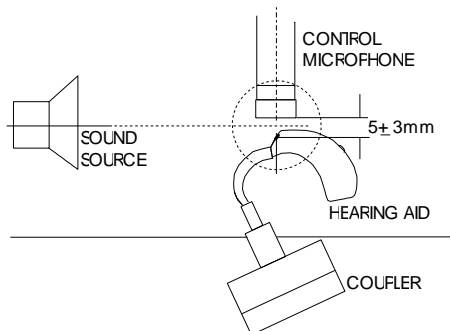

For maximum precision the hearing aid and the reference microphone should be placed symmetrically relative to the symmetry line as indicated on the sketch.

Positioning of Directional Hearing Aids

Place the hearing aid and the reference mic. According to the sketches:

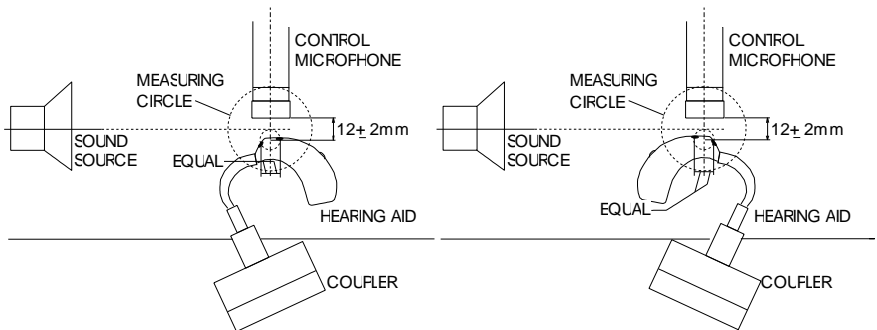

For maximum precision the hearing aid and the reference microphone should be placed symmetrically relative to the symmetry line as indicated on the sketch.

Positioning of ITE Hearing Aids

Exchange the blue foam with the coupler

Remove the blue foam indicating the test point. Now place the coupler and the attached ITE hearing aid at the test point and place the reference microphone 5mm (+/-3mm) from the HA microphone.

ITE hearing aids still on the face plate

If the face plate is positioned in a 90 degrees angle to the direction of the travelling sound wave, then a pressure built-up at higher frequencies will take place. For pure tone

stimulation the reference microphone positioned close by will of course detect this and make the needed correction.

With complex stimulation (e.g. noise) however, the face plate should be placed parallel to the travelling sound wave as the flat frequency response characteristics of the TBS25 only then will be present at the microphone of the hearing aid.

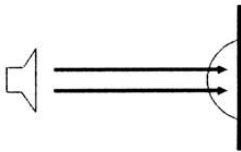

Pressure built-up at face plate. Increased high frequency energy

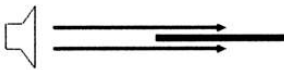

No pressure built-up at face plate. Correct frequency response

Positioning of Large devices

Avoid blocking or reflections of sound

The device to be tested (e.g. a body worn hearing aid) should be placed so that its case is not creating a block or a direct reflection of the test stimulus.

The resulting position of the microphone and the reference microphone should be similar to testing a BTE hearing aid.

Technical Considerations

Noise Rejection

Extreme conditions may call for optimizing

The noise insulating capabilities of the TBS25 will usually result in satisfactory performance. Under extreme conditions, however, the performance may need to be optimized.

The considerations below may answer questions that arise during such optimizing of performance:

The “Knock on the door” effect:

During tone sweep at high intensities you might be able to hear the tone outside the TBS25. This may seem to indicate poor noise insulation, arguing that airborne energy is attenuated equally much whether it is travelling from the inside outwards or outside inwards. However, these audible tones actually tell you nothing about the noise insulating capabilities of the TBS25.

The audibility of the tone is due to the “Knock on the door” phenomena: When you knock directly on a door the resulting sound on the other side of the door is much louder than it would have been if you were making the same noise by knocking on a piece of wood hanging in the air right next to the door.

Contrary to traditional designs the speaker inside the TBS25 is mounted firmly directly on the outer wall of the box itself. This procedure is chosen because it assures a reproduction without any uncontrolled resonances. However, with such mounting the motor system of the speaker will apply as much energy directly to the wall itself as it applies to the speaker membrane inside the box. Due to this direct coupling the wall is forced to vibrate somewhat thus acting as a loudspeaker membrane directly coupled to the *outside* air.

What you hear is due to this phenomena of the speaker system “knocking” directly on the inside of the wall of the box, much more than it is due to the acoustic energy of the air inside the box penetrating the walls.

Surface carried noise

The “knocking on the door” phenomenon described above also applies for any vibration reaching the surface of the box by mechanical contact. Such vibration will result in noise inside the box much more than noise reaching the box through the air.

For this reason the TBS25 should be placed n the standard mounting mat as it has some noise insulating capabilities. Heavy duty mats may be used to improve this type of noise insulation.

Sandwiched constructed mats, using layers of soft (foam) and hard (e.g. wood) materials may prove very effective.

Small feet should usually be avoided as the air gap between the table and the box will tend to act as a resonator, applying much more airborne noise to the bottom of the box at certain frequencies.

Room Resonances

As the TBS25 will usually be placed in a normal hard-walled room, resonances between the walls or between a wall and one or more of the surfaces of the TBS25 may apply energy to the TBS25 at certain frequencies at levels much higher than the general noise level in the room

If noise is entering the box try to change the position of the TBS25 or place some damping material on the suspected wall. Also a heavy duty noise insulating mat placed on top of the lid of the TBS25 may improve the noise insulating qualities.

The lid

The lid must be closed firmly for maximum noise rejection. Often however, just a slight fastening of the lid will prove to give sufficient noise insulation.

Distortion

The inherent distortion of the TBS25 is difficult to measure as it is very low. E.g. if you use the coupler microphone without a hearing aid attached and then carry out a traditional distortion measurement you will get distortion figures that do not reflect the performance of the TBS25. The reason for this is that distortion basically is high frequency noise and as the connected electronics will usually have a noise floor above the noise added by the distortion of the TBS25 this electrical noise floor is what is revealed by the distortion measurement.

Note

When distortion measurements are made on hearing aids the distortion figures are not influenced by this electrical noise as the acoustic output level is much higher when a hearing aid is attached, thus creating an electrical output from the coupler's microphone well above the electrical noise floor of the connected electronics.

Free Field Conditions

Directional microphones may be tested

Inside the TBS25 reflections have been minimized to create a test environment where it is possible to test the directionality of microphones.

Above approx. 500Hz approximated free field conditions exist so directional microphones may be tested with a reasonable accuracy. Please note, however, that documentation supplied from the supplier of e.g. hearing aids may be test results obtained on a KEMAR or similarly made in a way that makes it not directly comparable to the

results obtained in the TBS25. Please also note that the position of the reference microphone relative to a directional microphone arrangement affects the resulting response curve. A 12mm. distance is laid down by the ANSI S3.22 – 1982 Standard.

Free field conditions diminish below 500Hz

Below approx. 500Hz the limited physical dimensions of the test chamber causes the acoustic characteristics to be more and more like those of a pressure zone built-up but it still occurs to some degree. In a true pressure zone directional microphones do not exhibit directional characteristics

Optional testing of directional microphones with lid open

Opening the lid reduces the gradual pressure zone built up below 500 Hz. If external noise level allows, more accurate testing of directional microphones in the sub-500 Hz range may be possible by testing with the lid open. Please also see chapter "Open or closed lid".

Two tests shown for comparison

Below is shown the test results from a hearing aid with directional microphones as recorded in the TBS25 (and MS25). For comparison, the performance of the same hearing aid with directional microphones as obtained in a big anechoic room with true free field conditions present at all frequencies within the test range is shown.

Please note

- How the front to back difference is decreasing somewhat below approx. 500Hz.
- How the different reference microphone placement in the two tests has given different shapes to the curves
- That the two test results do not compare at low intensities due to a noise floor present at approx. 57dB in the true free field test situation.

TBS25

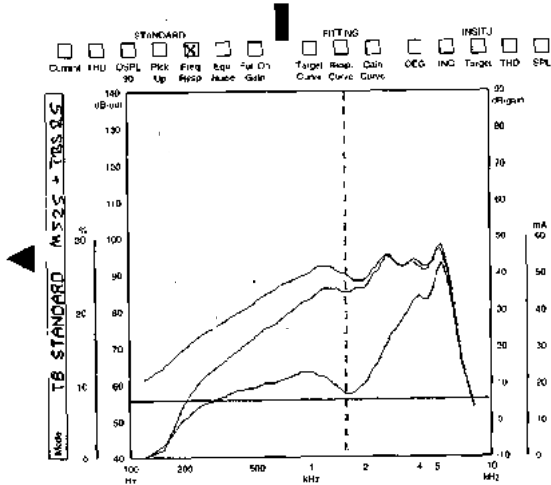

True Free-Field Conditions

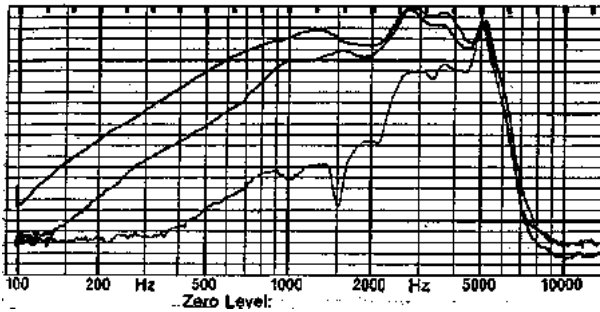

Frequency Response

Pure tone stimulus tailored by ref. mic.

When using pure tones as stimuli the sound stimulus will always be tailored by the function of a reference microphone and for this reason the basic frequency response of the test box is not very important.

When using noise stimuli, however, the accuracy of the spectrum must be within certain limits. The ANSI standard calls for +/- 3dB from 200 - 5kHz. This can be achieved with the TBS25 also without correction being applied to the electrical drive signal.

With a flat frequency response like that of the TBS25 the possibility of using very complex stimuli arises. For example, any electrical signal from a CD-player Affinity^{2.0} or Equinox^{2.0} or hearing aid analyzer will be available as a closely resembling acoustics duplicate at the test point of the TBS25.

As an example of the general quality of the TBS25 please find here a recording of the acoustic output when subjected to an electrical 600Hz triangular wave stimulation.

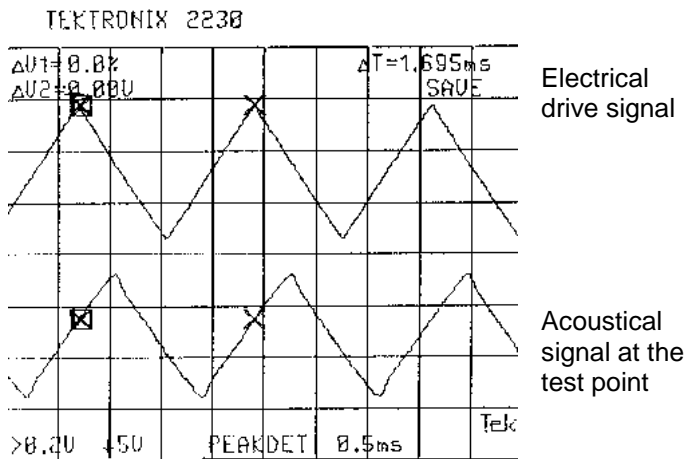

Measurement Circle

The correct placement of hearing aid microphone and reference microphone should be in such a way that they are both placed within the measurement circle indicated by the blue foam. They should have identical distances to the centre of the measurement circle and have identical distances to the speaker.

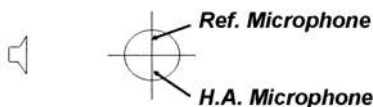

The typical uniformity of the sound field within the measurement circle is ± 1 dB from 20Hz to 10kHz. Less deviation is observed when comparing only sound levels on a line perpendicular to the direction of the sound wave.

Open or Closed Lid

The flat frequency response of TBS25 is only present when the lid is closed.

When performing pure tone testing the changed frequency response present when the lid is open should not bother you as it will be compensated for by the reference microphone.

When testing with complex signals like noise the most accurate results will be obtained when the lid is closed, as the correct triggering of the nonlinear circuits in the hearing aid is determined by a correct shape of the noise signal. This shape may be distorted too much when the lid is open. Analyzer dependant.

The typical frequency responses for the TBS25 with the lid closed and with the lid open is shown below and on the next page (Please note that these curves indicate the typical basic response of the TBS25 and that the small deviations from the perfect flat curve are

not reflected in hearing aid measurement curves for pure tones made with TBS25, as the accuracy of such measurements are determined by the accuracy of the reference microphone.

Typical frequency response with lid closed:

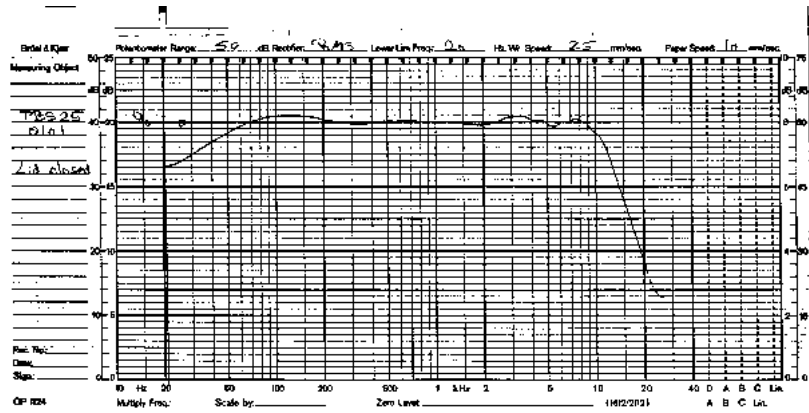

Typical frequency response with lid open in normal room:

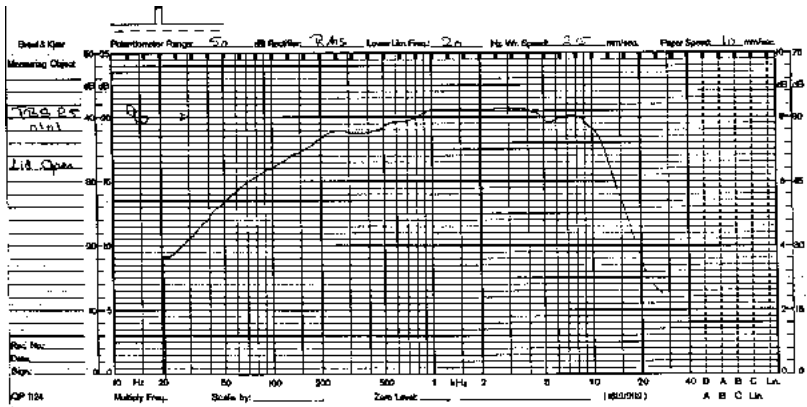

Technical Specifications

Standards

Safety: EN 60601-1
Hearing Aids: EN 60118-0

Medical CE-mark



The CE-mark indicates that Interacoustics A/S meets the requirements of Annex II of the Medical Device Directive 93/42/EEC. TÜV Product Service, Identification No. 0123, has approved the quality system.

Noise Rejection

Depending on placement and acoustic surroundings:
20 Hz - 300 Hz: 45dB - 70dB.
Above 300 Hz: 45dB - 55dB.

Acoustic Distortion

At 100dB SPL at any frequency between 100Hz and 8kHz the typical distortion is:
2nd: < 0.05% and 3rd: < 0.3%
Lower distortion at lower intensities.
TDH at 70dB SPL: Too low to be measured by traditional techniques.

Input

1 watt: 110dB SPL at test point. Max. input: 4.5 watts continuous. 40 watts short term.

Impedance

Nominal 8 ohm. (max. 25 ohm).

Accuracy of Hearing Aid Response Curves

Determined by quality of reference microphone.

Frequency Range

These specifications indicate typical performance prior to any applied electronic correction.
50Hz - 8kHz +/- 1.5dB
3dB points at 35Hz and 10kHz.
6dB/octave cut off below 35Hz.

24dB cut/octave cut off above 10kHz. Neither slope suffers from disturbing resonances.

Uniformity of Sound Field

In measuring area typically +/- 1dB, 20 Hz - 10kHz.

Stimulation Level

Available levels determined by specifications of connected analyser.

Upper limit: Above 110dB SPL

Lower limit: Determined by ambient noise level

50dB SPL test level at 75dB ambient noise changes measurement less than 0.5dB.

35dB SPL test level at 70dB ambient noise has a signal to noise ratio exceeding 10dB.

Sound Presentation

Via high quality loudspeaker unit.

Acoustic Environment

Approximates to Free Field conditions above 500Hz.

Horizontal sound radiation.

External / Internal Connections

Reference microphone.

Coupler.

Battery adapter.

Loop.

2 x Auxiliary

Speaker.

Additional cables through sound proof passage.

Construction:

Painted comonite cabinet.

Dimensions:

Net weight: 22 kg / 48.5 lbs.

Size: L x W x H: 40 x 36.5 x 26 cm. / 15.7 x 14.4 x 10.2 inches.

Dimensions of Test bed

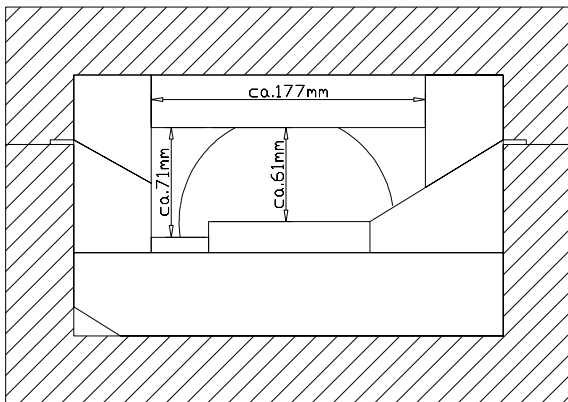
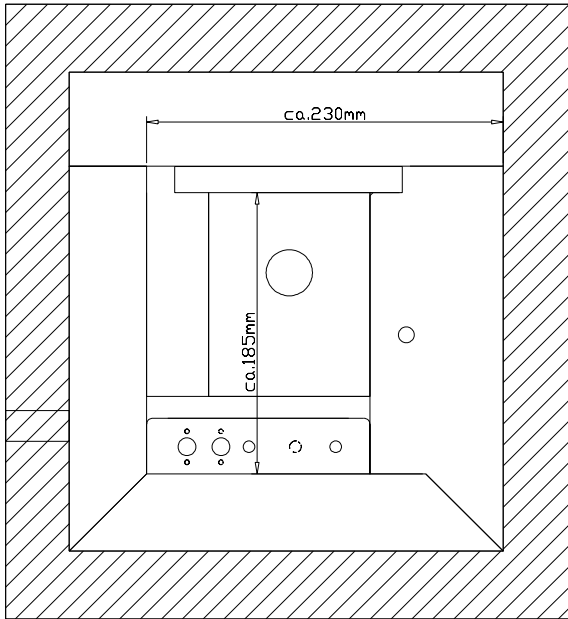

Connection Panel

External Connection Panel

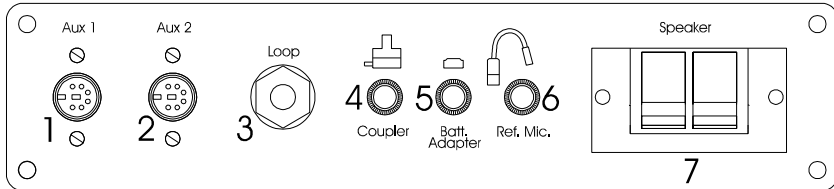

Position:	Symbol:	Function:
1	Aux 1	Connector for Aux 1
2	Aux 2	Connector for Aux 2
3	Loop	Connector for telecoil loop
4	Coupler	Connector for coupler
5	Batt. Adapter	Connector for battery adapter
6	Ref. Mic.	Connector for reference microphone
7	Speaker	Connector for built-in speaker

Internal Connection Panel

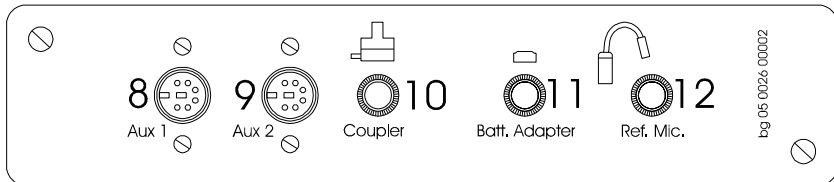

Position:	Symbol:	Function:
8	Aux1	Connector for Aux 1
9	Aux 2	Connector for Aux 2
10	Coupler	Connector for coupler
11	Batt. Adapter	Connector for battery adapter
12	Ref. Mic.	Connector for reference microphone

Technical specifications for built-in loop

The loop in TBS25 is placed in the left and right side of the box. These two loops are simultaneously driven and provides a horizontal magnetic field in the left / right direction. Orientation of the hearing aid under test should of course be positioned in accordance with this. The loop itself has very low impedance. Driving it will therefore be a question of either having a constant current source or driving it with a traditional amplification device through a load resistor.

The table below shows the relation between magnetic field strength and current through the loop:

Current through loop	Field strength
25 mA	100 mA/m
2.5 mA	10 mA/m

The field strength varies with position. However, a very good homogeneous field has been obtained. The table below shows variation relative to the test point (centre of blue foam).

Position	Variation in magnetic field strength
Test point	0
2 cm from test point	0.5 dB
4 cm from test point	2.5 dB

Note

From the factory both Affinity^{2.0} and Equinox^{2.0} are adjusted to deliver field strength for the loop system of 10mAm Or 31.6mAm depending on the standard chosen.

Using Internal Wiring for Standard Microphone

The auxiliary connectors which may be used for HiPro connection may also serve as direct cabling for professional microphone capsules. Connecting cables developed for this purpose is available from a Danish manufacturer of professional microphones, G.R.A.S. Further details may be found at www.gras.dk.

Same manufacturer has a reduced sized preamplifier, which will fit nicely inside the TBS25. B&K microphone capsules as well as other high quality microphones capsules are in this way easy to use with the TBS25.

Unpacking / Inspection

Check box and contents for damage:

When the instrument has been received, please check the shipping box for rough handling and damage. If the box is damaged it should be kept until the contents of the shipment have been checked mechanically and electrically. If the instrument is faulty, please contact the nearest service office. Keep the shipping material for the carrier's inspection and insurance claim.

Store carton for future shipment

The TBS25 comes in its own shipping carton, which is specially designed for the TBS25. Please store this carton. It will be needed if the instrument has to be returned for service.

If service is required, please contact your nearest sales and service office.

Contents of Shipment

When TBS25 is delivered with standard accessories the case contains the following:

Quantity	Item	Order No.
1	Instrument TBS25	TBS25
1	Mounting Mat	TMM25
3	Connection Cables	TCC25
1	Loop Cable	TCL25
1	Speaker Cable	LSC25
1	Cable kit for connecting TBS25 to Affinity	70883
1	Operation manual	57396
1	CE-manual	57584

Check numbers on TBS25 and Manual:

The identification label on the back of the TBS25 holds the serial number. This should be checked with the manual number and written down for later service claims.

Reporting Imperfections

Inspect before connection:

Prior to connecting TBS25 to the hearing aid analyzer it should once more be inspected for damage. All of the cabinet and the accessories should be checked visually for scratches and missing parts.

Report immediately any faults:

Any missing part or malfunction should be reported immediately to the supplier of the instrument together with the invoice, serial number and a detailed report of the problem. In the back of this manual you will find a "Return Report" where you can describe the problem.

Please use "Return Report":

Please realize that if the service engineer does not know what problem to look for, he may not find it. Therefore using the Return Report will be of great help to us and at the same time it is your best guarantee that the correction of the problem will be to your satisfaction.

Trouble Shooting

The following is displayed: “Control that loudspeaker and Ref. Mic. are connected.”

Check that the ref. mic. Is connected to its socket inside the TBS25.

Check that the cable connecting TBS25 to the analyzer is connected to the appropriate sockets, and that the jacks are fully inserted. To check for faults inside the cables, you may interchange them.

Check that the speaker cable is inserted into the TBS25 speaker inlet in such a way that the uninsulated cable ends are making electrical contact to the metal teeth inside the connector.

Check that the correct speaker outlet on MS25/MS40 is used. It should be the one labelled “Ext. Lsp Testbox” and not the one labelled “Ext Lsp” right above the insitu headset connector.

The following is displayed: “Too much environment noise!”

The hearing aid is oscillating. Make sure the connection from the hearing aid to the silicon tube of the coupler is OK. If the hearing aid still oscillates, turn down its volume control slightly.

Noise I entering the box. Close the lid firmly. See chapter “noise Rejection” of this manual for methods of reducing the noise level inside the box.

No signal present when testing telecoil:

Make sure the telecoil is selected on the hearing aid.

Check that the telecoil cable is connected correctly to the hearing aid analyzer.

Hearing aid does not function when connected to battery outlet inside TBS25:

Assure that the jack of the battery adapter is inserted correctly into its socket.

Check that the battery adapter is making good contact inside the hearing aid and that it is not broken.

Check if the hearing aid operates when the battery adapter is connected directly to the analyzer. If it does check that the cable between the analyzer and TBS25 is connected correctly and that the jacks are fully inserted.

Check for faults inside the cable by interchanging it with one of the other cables.

Flat response curves:

Assure that the coupler is connected correctly.

Assure that the battery adapter is connected correctly.

Appendix A: Service Kit



Lock

Part number 43380



HTB25 Handle

Part number 49199



Speaker

Part number 46339



Set of Gas Springs

Part number 45343 x 2



Connection Panel outside

Part number 40792



Connection Panel inside

Part number 40790



Set of Loop Coils

Part number 54518 x 2

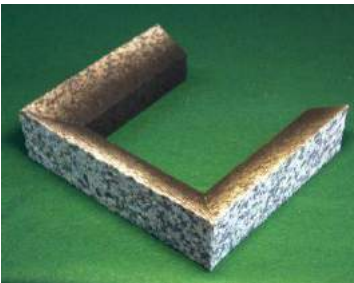

Foam Bottom Sides

Part numbers:

52837 Front

52836 Left

52837 Right



Foam for Speaker

Part number 52796



Foam for Test Bed

Part number 52795



Set of Foam Cushions for lid

Part number 49201



Set of Felt for Lid

Part number 49202



Set of NTBS25 Neoprene Surfaces

Part number 49206



Neopren Mat

Part number 52756



Hinge

Part number 46248

Appendix B: General Maintenance Procedures

The performance and safety of the instrument will be kept if the following recommendations for care and maintenance are observed:

- It is recommended to let the instrument go through at least one annual overhaul, to ensure that the acoustical, electrical and mechanical properties are correct. This should be made by an authorized workshop in order to guaranty proper service and repair.
- Before the connection to the mains network, be sure that the local mains voltage corresponds to the voltage labelled on the instrument. Always disconnect the power cord if the instrument is opened or by control / replacement of the mains fuses.
- Observe that no damage is present on the insulation of the mains cable or the connectors and that it is not exposed to any kind of mechanical load, which could involve damage.
- Consult the Operating Manual for the instrument in question to see how long time it takes from turning on the instrument until it is stabilized and ready to use.
- For maximum electrical safety, turn off the power from a mains powered instrument when it is left unused.
- Do not site the instrument next to a heat source of any kind, and allow sufficient space around the instrument to ensure proper ventilation.
- To ensure that the reliability of the instrument is kept, it is recommended that the operator at short intervals, for instance once a day, perform a test on a person with known data. This person could be the operator him/herself.

- A plastic cover can be provided to protect the instrument against the accumulation of dust. The cover should only be used when the instrument is left unused with the power turned off.
- If the surface of the instrument or parts of it is contaminated, it can be cleaned using a soft cloth moistened with a mild solution of water and dish washing cleaner or similar. The use of organic solvents and aromatic oils must be avoided. Always disconnect the mains conductor during the cleaning process, and be careful that no fluid is entering the inside of the instrument or the accessories.
- After each examination of a patient, it should be ensured that there is no contamination on the parts in connection with the patient. General precautions must be observed in order to avoid that disease from one patient is conducted to others. If ear cushions or ear tips are contaminated, it is strongly recommended to remove them from the transducer before they are cleaned. By frequent cleaning water should be used, but by severe contamination it may be necessary to use a disinfectant. The use of organic solvents and aromatic oils must be avoided.
- Great care should be exercised by the handling of earphones and other transducers, as mechanical shock may cause change of calibration.

rn Report – Form 001



Opr. date: 2003-02-24 by: EC Rev. date: 2003-02-24 by: EC Rev. no.: 1

Company: _____

Address: _____

Phone: _____

Fax: _____

Contact person: _____

Address

Drejervænget 8
DK-5610 Assens
Denmark

Phone

(+45) 63713555

Fax

(+45) 63713522

Date : _____

Following item is reported to be:

- returned to INTERACOUSTICS for: repair, exchange, other: _____
- defective as described below with request of assistance
- repaired locally as described below
- showing general problems as described below

Item:

Type: _____

Quantity: _____

Serial No.: _____

Supplied by: _____

Included parts: _____

Description of problem or the performed local repair: _____

Returned according to agreement with: Interacoustics, Other : _____

Date : _____

Person : _____

The above mentioned item is reported to be dangerous to patient or user ¹

In order to ensure instant and effective treatment of returned goods, it is important that this form is filled in and placed together with the item.

Please note that the goods must be carefully packed, preferably in original packing, in order to avoid damage during transport. (Packing material may be ordered from Interacoustics.)

¹ EC Medical Device Directive rules require immediate report to be sent, if the device by malfunction deterioration of performance or characteristics and/or by inadequacy in labelling or instructions for use, has caused or could have caused death or serious deterioration of health to patient or user.